

Operating Instructions

VAREOTRON MFR 330

Frequency Converter for Three Phase AC Motors
esp. for conveying belt drives

Enclosed version

REO ELEKTRONIK GMBH
Fertigung
Erasmusstraße 14
D-10553 Berlin
Tel. (030) 349928-0
Fax (030) 349928-88
<http://www.reo.de>
eMail: sales@reo.de

REO ELEKTRONIK GMBH
Entwicklung + Vertrieb
Brühler Straße 100
D-42657 Solingen 1
Tel. (0212) 8804-0
Fax (0212) 8804-188
<http://www.reo.de>
eMail: sales@reo.de

VAREOTRON
Steuergeräte für die Antriebstechnik

Technical Safety Information for the User

This description contains the necessary information for the correct application of the product described below. It is intended for use by technically qualified personal.

Qualified personnel are persons who, because of their training, experience and position as well as their knowledge of appropriate standards, regulations, health and safety requirements and working conditions, are authorised to be responsible for the safety of the equipment, at all times, whilst carrying out their normal duties and are therefore aware of, and can report, possible hazards (Definition of qualified employees according to IEC 364)

Safety Instructions

The following instructions are provided for the personal safety of operators and also for the protection of the described product and connected equipment.



Warning!
Hazardous Voltage
 Failure to observe can kill, cause serious injury or damage

- Isolate from mains before installation or dismantling work, as well as for fuse changes or post installation modifications.
- Observe the prescribed accident prevention and safety rules for the specific application.
- Before putting into operation check if the rated voltage for the unit conforms with the local supply voltage.
- Emergency stop devices must be provided for all applications. Operation of the emergency stop must inhibit any further uncontrolled operation.
- **Electrical connections must be covered**
- **The earth connection must be checked, for correct function, after installation.**
- **After switching off the unit, some internal components will still be charged due to capacitance.**
- **Before opening the unit wait at least five minutes to allow capacitors to discharge.**

Specified Use

The units described herein are electrical controllers for installation in industrial plant. They are designed for controlling three phase AC motors.

Contents

Technical Safety Information for the User	1
1.0 General	2
2.0 Functions	2
2.1 Track Control	3
2.2 Control In- and Outputs	3
3.0 Construction	3
4.0 Technical Data	4
4.1 Conformity Declaration	4
5.0 Ordering Codes	4
6.0 Operating Elements	5
7.0 Installation	5
8.0 Settings	6
9.0 Setting Instructions	6
10.0 Error Messages	8
11.0 Connections	9
12.0 Dimensions	10



1.0 General

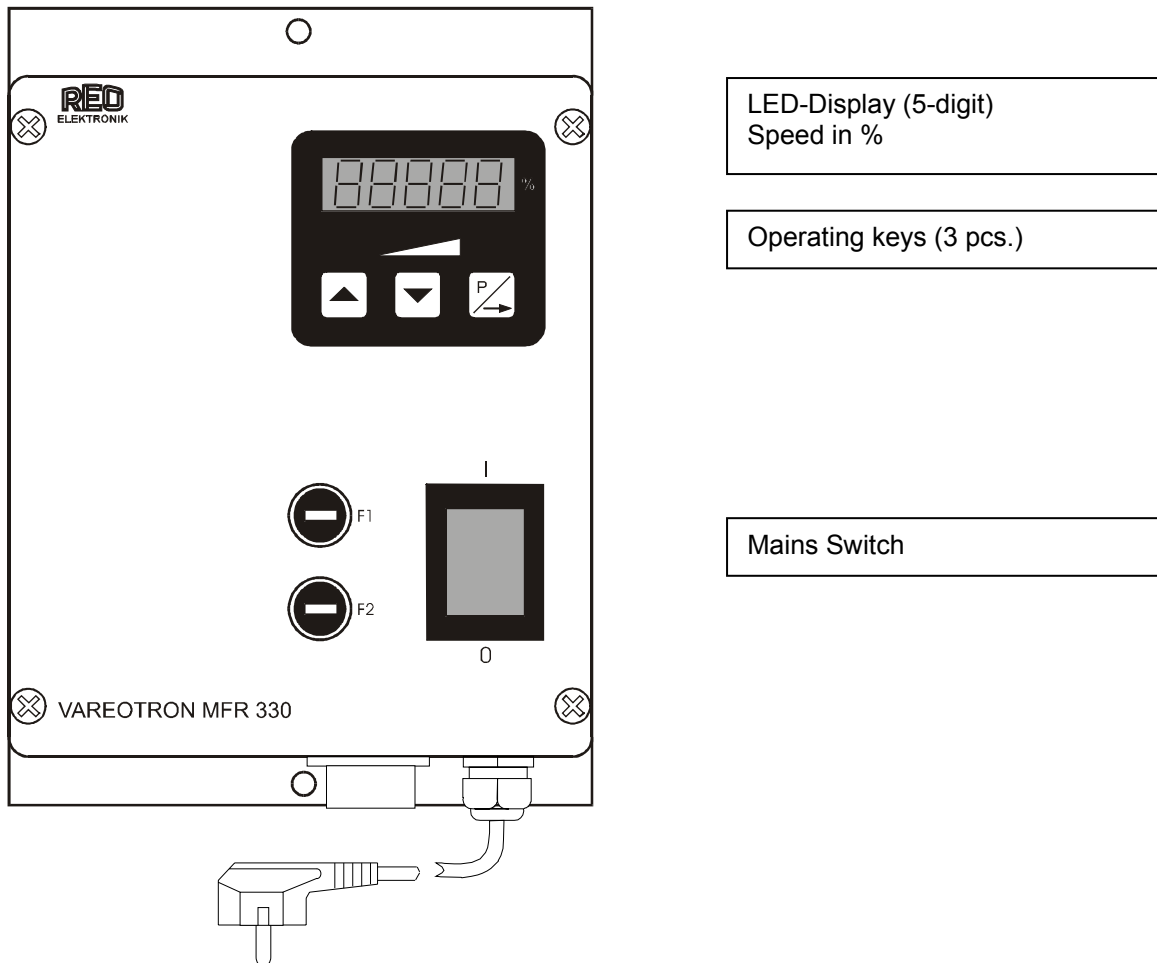

The range of VAREOTRON MFR 330 regulators are microprocessor based units for controlling the speed of three phase AC motors. The controllers produce a frequency which is independent of mains frequency to drive the motor, the adjustable frequency range is 2...120 Hz.

The display in the front panel shows the relative speed in percent. Especially for the use in material feed systems, an integral control circuit for the material flow (track controller) is provided. The unit accepts any 24 V, PNP sensors for the track controller. The enclosed version (IP 54) enables the assembly (in a vibration-free place) on the feeding device.

2.0 Functions

The unit is operated by using three buttons, which are provided together with an LED display, in a touch panel on the front plate. The motor speed adjustment and setting of other parameters can be carried out by using these components. The parameters can be changed by scrolling through a setting menu, which is accessed by a user password. The various functions within the menu are explained in detail in the chapter on the settings.

The speed set point is shown in % (0...100 %), on the LED display, during normal operation. In the programming mode the dimensions are entered according to the setting instructions. Changed settings are saved when leaving the programming mode or after a 30 second delay from when the last key was pressed.

2.1 Track Control

The track control determines the running time of a feeder, for example, in a way that reduces unnecessary operating time. The motor is switched On and OFF from a component sensor, after the integral adjustable time delays („t on“ and „t off“) have elapsed.

In this way the component level is regulated around the position of the track sensor. The motor of the feeder is switched on when the product level falls below the sensor and the switch-on time delay has expired. Components are now fed onto the track again. Once the product level builds up past the sensor position, the switch-off time delay is activated and when it elapses the motor of the feeder is switched off. Gaps in the feed reset the timers and so that the time from the last component to the first is always exactly the same. The on and off switching time delays are set in the programming menu. The decimal point, in the display, flashes to indicated that the time delay is operating. An additional time delay „Sensor Time-out“ can be started when the feeder unit is switched on. This can be set from 30 to 240 seconds and causes the feeder to switch off if no product is detected by the sensor during this time. A status relay also switches off when the feeder is switched off and the display flashes with an alternating message „Error/SE“. In order to activate this function, it must be switched on with the function „E.E.“ in the menu track control (C 007).

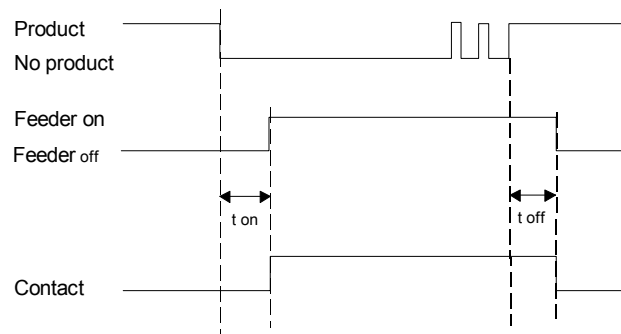

2.2 Control In- and Outputs

Control inputs:

Sensor for track control: 24 V, DC (PNP)

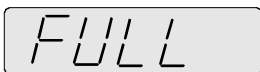

Display for motor switched off from sensor (track control)

Enable: Switch or voltage signal 12-24 V, DC

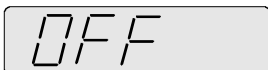

Display for no enable present

Control output:

Status-Relay

Relay contact 250 V/1 A (Change-over). Relay closes when feeder is running – relay opens when enable signal is missing or if there is a fault

3.0 Construction

The controller unit is a completely wired, function tested, compact unit with the following features:

- Mains switch and fuses
- Operating and display panel
- Mains connecting cable with shock-proof plug
- Metal output flange socket for connecting the three phase AC motor
- A connector socket is built into the wall of the enclosure when the unit is used with track control. This is designed for use with standard 24 V DC sensors with a PNP output.
- When additional functions such as external enable, external set point or status relay are used, an additional cable gland must be fitted into a tapped hole provided, which is closed with a blind stopper.

4.0 Technical Data

Type	VAREOTRON MFR 330.01
Supply voltage	230 V +6 % -10 % 50/60 Hz
Output voltage	0-220 V
Output frequency	2 - 120 Hz
Motor capacity	370 W
Ramp-up time	0...15 secs.
Ramp-down time	0...15 secs.
Sensor supply	24 V, 25mA
Switch on time delay t_{ein}	0...15 secs.
Switch off time delay t_{aus}	0...15 secs.
Empty time t_{err}	30...240 secs.
Set point source	Keys / 0...10 V, 0(4)...20 mA, DC
Enable	12-24 V, DC / Switch
Status relay	1 change-over 250 V, 1 A
Ambient temperature	0-45 °C
Dimensions (W x H x D)	90 x 205 x 185 mm
Enclosure rating	IP 54

4.1 Conformity declaration

5.0 Ordering codes

Description	ID-Number	Brief description
VAREOTRON MFR 33001	33001	Control unit with track control

6.0 Operating elements:

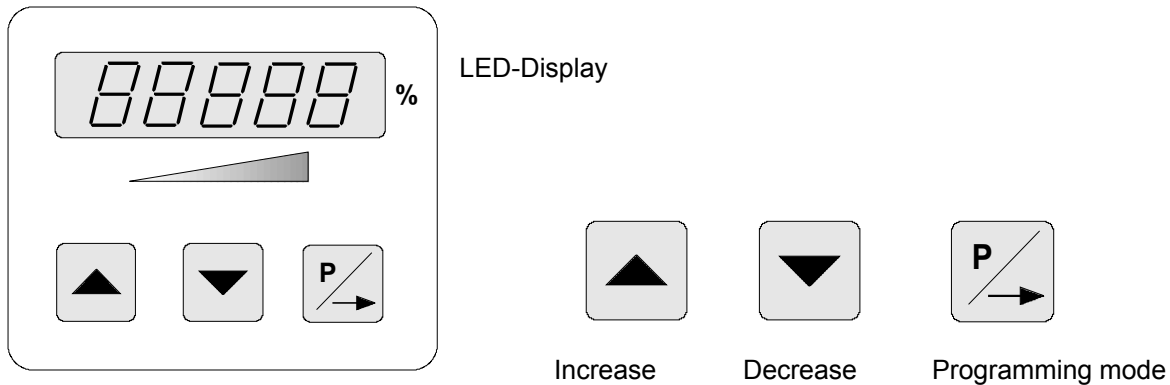

Setting features:

The display steps up (or down) by one digit (or one tenth) when the cursor keys are pressed. If the cursor key is held down the display will jump to the next multiple of ten and in steps of ten thereafter.

The settings are protected to prevent accidental or unauthorised changes. To enter the setting menu a pass code must be entered. There are different passwords provided for each setting level.

Value changes are automatically saved when leaving the programming mode or if no keys are pressed for 30 seconds.

In case of accidental value changes, the factory settings (FAC) or the settings saved by the user (USPA) can be back loaded using the code „C210“.

7.0 Setting-up instructions

Recommended procedure:

- Check that the local voltage is correct for the voltage stated on the rating plate and that the output voltage is suitable for the feeder unit which is connected to the controller.
- Connect the control unit according to the wiring diagram provided.
- Adjust the set point to zero.
- Switch off the enable (if used)

The unit is now, basically, ready to run and can be switched on (mains and enable).

Should it be necessary to adjust any settings the procedure is as follows:

8.0 Settings

All settings can be made by using the three buttons on the front panel.

Parameter		Designation	Factory basical setting	Pass code C
• Motor speed set point in %	0...100 %	S.	0 %	002, 008
• Minimum motor speed	0...100 %	A.	0 %	008
• Output frequency range	2...120 Hz	F.	50 Hz	008
• 2. Speed set point Coarse/Fine	0...100 %	2.	not active	008
• Ramp-up time	0...15 sec.	/	1 sec.	008
• Ramp-down time	0...15 sec.	\	1 sec.	008
• Change-over for using an external set point source	0 / 1	E.S.P.	0	003
• 4...20 mA set point	0 / 1	4.20	0	003
• Sense of rotation reversal	0 / 1	LE.	0	003
• External sense of rotation reversal	0 / 1	E.LE.	0	003
• Switch-over coarse/fine	0 / 1	S.P.2	Filling level	007
• Switch-on time delay	0...15 sec.	I	5 sec.	007
• Switch-off time delay	0...15 sec.	O	5 sec.	007
• Invert sensor function	PNP / PNP invers	-SE.	PNP	007
• Empty time delay (Sensor Time-out)	30...240 sec.	E.E.	not active	007
• Save adjusted parameter		PUSH		143
• Return to basic factory settings		FAC		210
• Return to adjusted parameters (stored with Code 143)		US.PA.		210

The change-over for using an external set-point (0...10 V resp. 4...20 mA) and an external sense of rotation reversal can be used only with option, with additional connector plug.

9.0 Setting instructions

Adjustment of the unit

Operator

Code 002

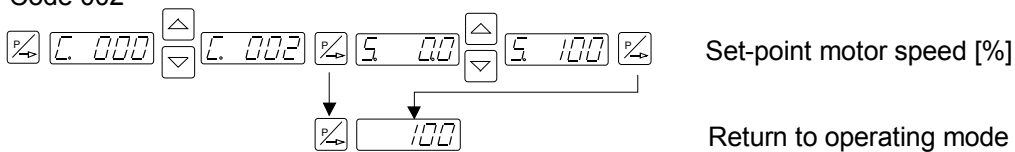

Set-up man

Code 008

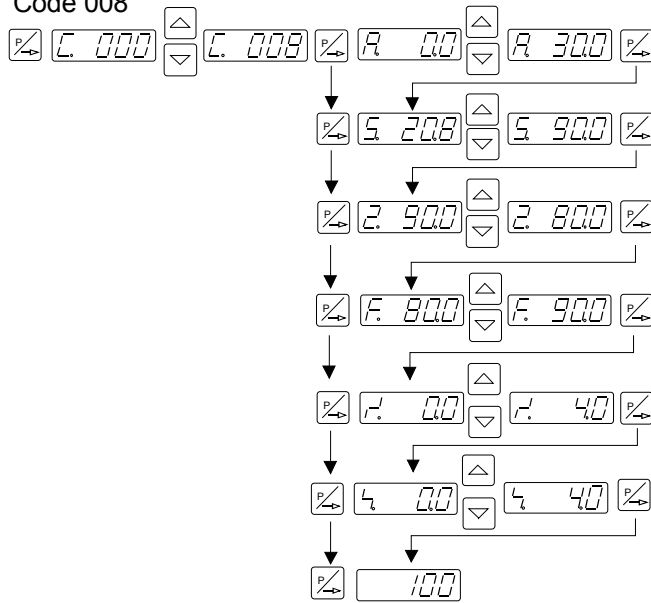

Minimum speed [%]

Set-point speed [%]

2nd set-point speed [%]
(if selected in menu 007)

Motor frequency (2...120 Hz)

Run-up time motor [sec.]

Run-down time motor [sec.]

Return to operating mode

Code 007

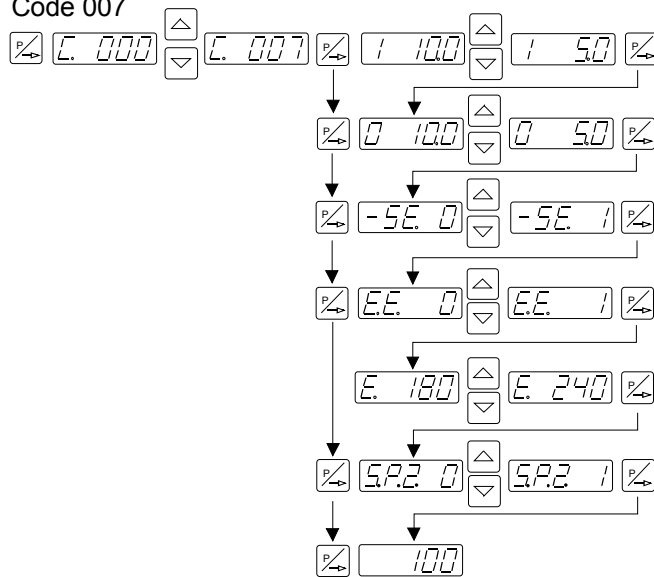

Switch-on time delay [sec.]

Switch-off time delay [sec.]

Invert sensor function

E.E = 0 = Sensor Time-out not active
E.E = 1 = Sensor Time-out active

E. = Time-out [sec.], (only if EE = 1)

Switch-over to coarse/fine control
with 2nd set-point

Return to operating mode

Code 003

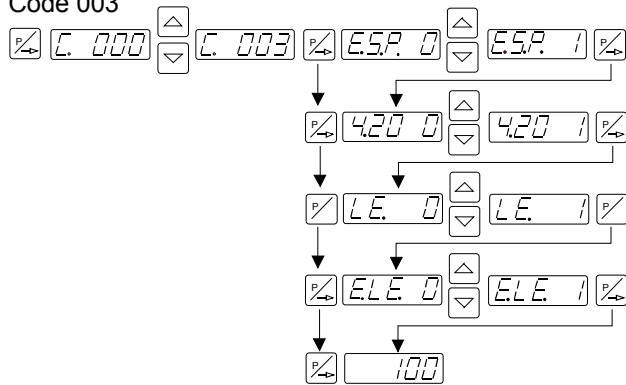

E.S.P. = 0 => Set-point over display (Standard)
 E.S.P. = 1 => external set-point (Option)

External set-point = 4...20 mA (only with ESP=1)

Sense of rotation reversal

External sense of rotation reversal (Option)

Return to operating mode

Code 143

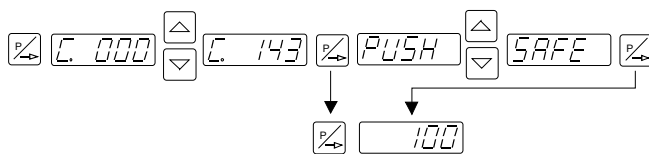

Save adjusted parameters

Return to operating mode

Code 210

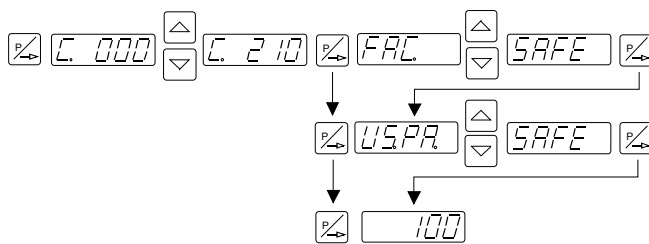

Return to factory settings

Return to parameters adjusted by set-up man

Return to operating mode

10.0 Error messages:

Over load limiting

The output power of the unit is monitored by indirect measurement of the current. When excessive current is detected, the unit switches off the output power and the display flashes, with an alternating message



Over voltage:

When excessive mains input voltage is detected, the power output is switched off and the display flashes, with an alternating message



Sensor Time-Out

When the function sensor time-out is active, the power output is switched off after the time-out time adjusted has expired, and the display flashes with an alternating message

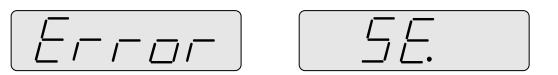

The unit is reset by pressing the „P“ key or by switching the power switch on and off.

11.0 Connections

Connection of the motor output socket

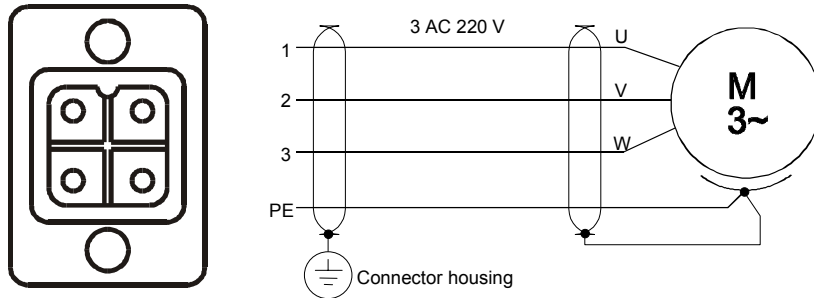

The screen of the output cable must be layed on the housing of the connector.

The output voltage of the units is 3 x 220 V, the motor windings must be wired corresponding to the motor used.

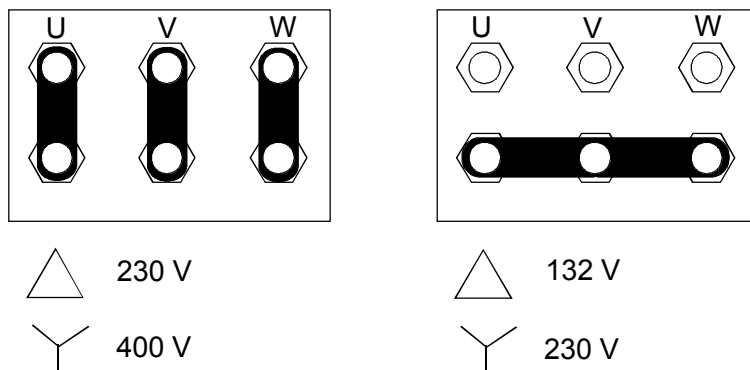

To conform with EMC requirements, a screened output cable for the motor must be used. This must be bonded, to earth potential, at both ends.

Connection of the material sensor

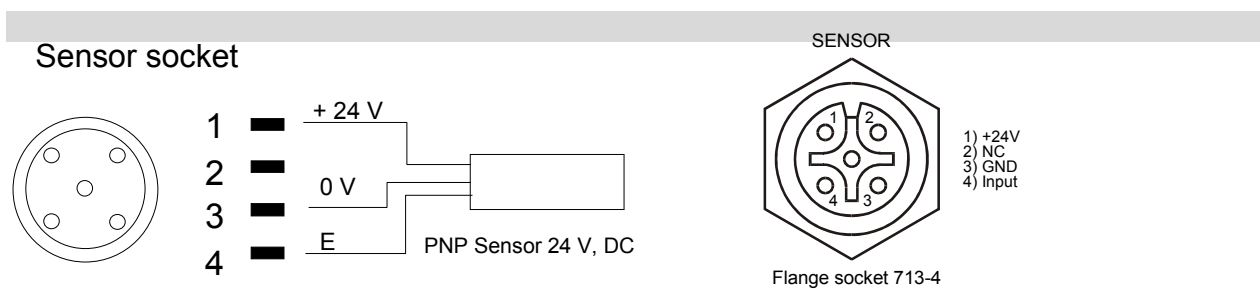

12.0 Dimensions

