

**Thyristor control unit for use with vibratory feeder units**

The REOVIB 506 range of control units are suitable for powering vibratory feeders which have a mechanical vibrating frequency which is the same as, or double that of mains frequency. The adjustment of feeder throughput is achieved by using a triac with phase angle control. The setpoint for the feeder throughput can be derived from a potentiometer. The set point range can be adjusted to suit the feeder unit by using trimmers (see "effects of trimmers Umin/Umax").

The units can operate with feeders which have a mechanical vibrating frequency 50 Hz or 100 Hz, ie 3000/6000 vibs/min (for 60 Hz mains supply this would be 60 Hz or 100 Hz, ie 3600/7200 vibs/min). The vibrating frequency is determined internally. An enable input is provided on terminals 1 and 2 for power free switching of the output (eg from a PLC).

To prevent surges when the unit is switched on, a soft starter is provided. This soft starter becomes effective with all switchings (mains "ON", enable "ON") and with set point adjustment. The semiconductors are protected against short-circuit current by an internal short-circuit fuse.

The output voltage of the unit is fed back internally and compared with the adjusted set point in a regulating device. Deviations which may be caused by mains variations or load changes are adjusted correspondingly.

The unit is supplied in a simple to install modular housing which is suitable for DIN rail mounting (EN 50022-35). The terminals have safety covers, according to VBG 4 standards.

**Technical data**

Type REOVIB 506	50606
Supply voltage	230 V, + 6 % / - 10 %, 50/60 Hz
Output voltage	0 ... 220 V
Output current	0,5 ... 2 A
Frequency	3000/6000 vibs./min (switchable)
Set point source	Potentiometer 10 kΩ
Enable input	Contact / 12...24 V, DC signal voltage Ri 10 kΩ
Ambient operating temperature	0...45 °C
Dimensions (h x w x d)	74 x 45 x 125 mm
Protection	IP 00
Other standards	IEC 801-2, IEC 801-4, EN 50081-1, VBG 4



**Specified Use**

The units described herein are electrical controllers for installation in industrial plant. They are designed for power adjustment to resistive and inductive loads.

**Dimensions drawing**

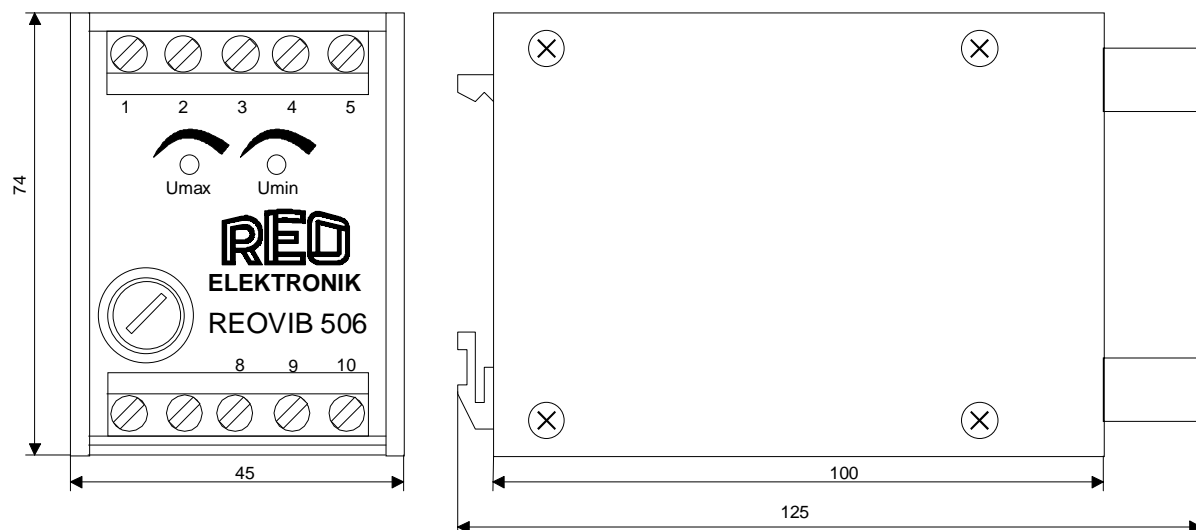

Ordering code: REOVIB 506

ID-No. 50606

**Technical Safety Information for the User**

This description contains the necessary information for the correct application of the product described below. It is intended for use by technically qualified personal.

**Safety Instructions**

The following instructions are provided for the personal safety of operators and also for the protection of the described product and connected equipment.



**Warning!**

Hazardous Voltage.  
 Failure to observe can kill, cause serious injury or damage.

- Isolate from mains before installation or dismantling work, as well as for fuse changes or post installation modifications.
- Observe the prescribed accident prevention and safety rules for the specific application.
- Before putting into operation check if the rated voltage for the unit conforms with the local supply voltage.
- Emergency stop devices must be provided for all applications. Operation of the emergency stop must inhibit any further uncontrolled operation.
- **The electric connections must be covered!**
- **Earth connection must be checked for safe function after assembly!**

**Connection drawing and Settings**

The switch-over of the mechanical vibrating frequency and the effect of the control input inhibit/enable are realised with the jumpers S1 and S2. To do this, it is necessary to remove the left side cheek of the enclosure.



**Attention!**  
 This input is at mains potential!

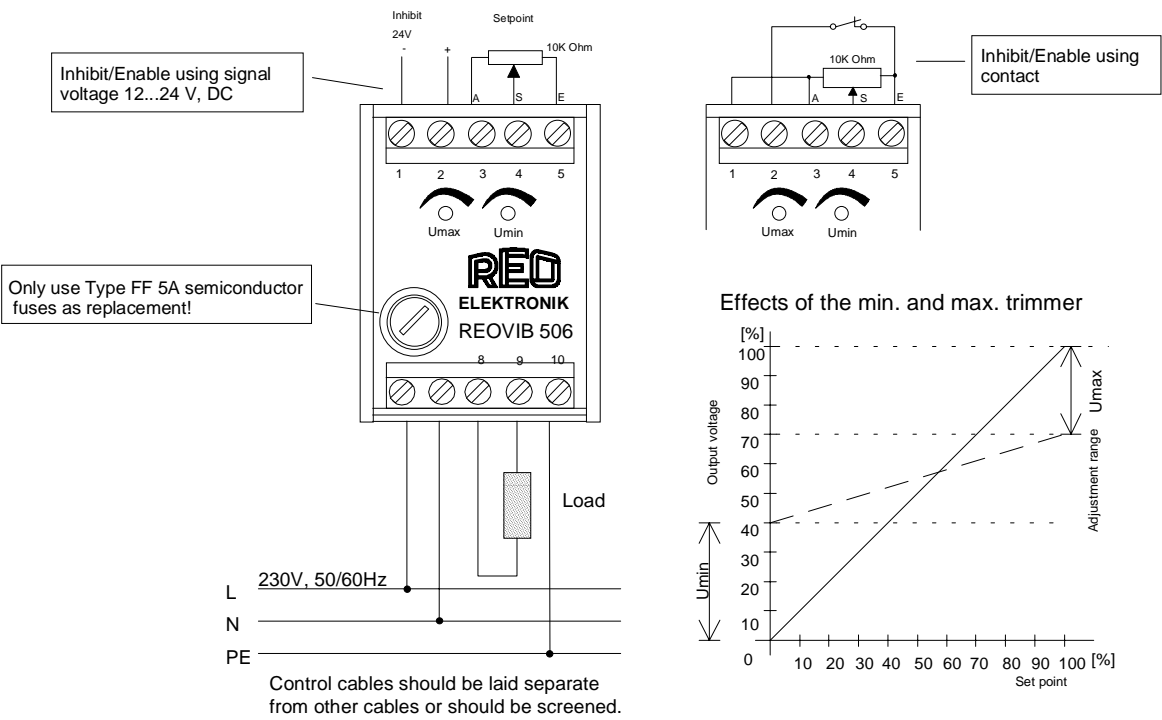

Effects of the min. and max. trimmer

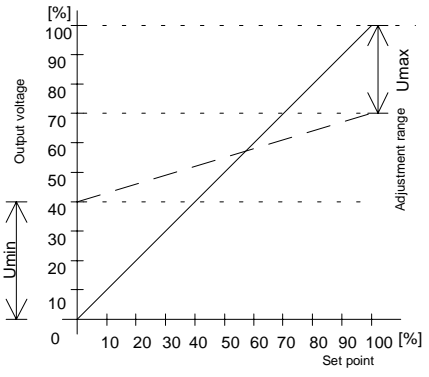

**Adjustment:**

- Connect controller according to diagram.
- Adjust setpoint to minimum and inhibit unit.
- Switch on mains supply and enable unit.
- Slowly increase the setpoint to maximum and monitor the load condition (if possible measure the voltage and current).
- On reaching maximum, limit the output with trimmer  $U_{max}$  and then set the minimum set point value with trimmer  $U_{min}$ .

