

REOV B MTS 442 and MTS 440
Com bination Round-Linearfeeder and Hopper

- SENSOR FOR TRACK CONTROL ON LINEARFEEDER AND HOPPER
- AIR VALVE VOR REJECT
- CONTROL INPUT START /STOP
- STATUS OUTPUT ON /OFF
- SENSOR MONITORING (TIME OUT).

24 V,DC SENSOR CONTROL (Time out)

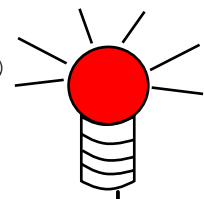

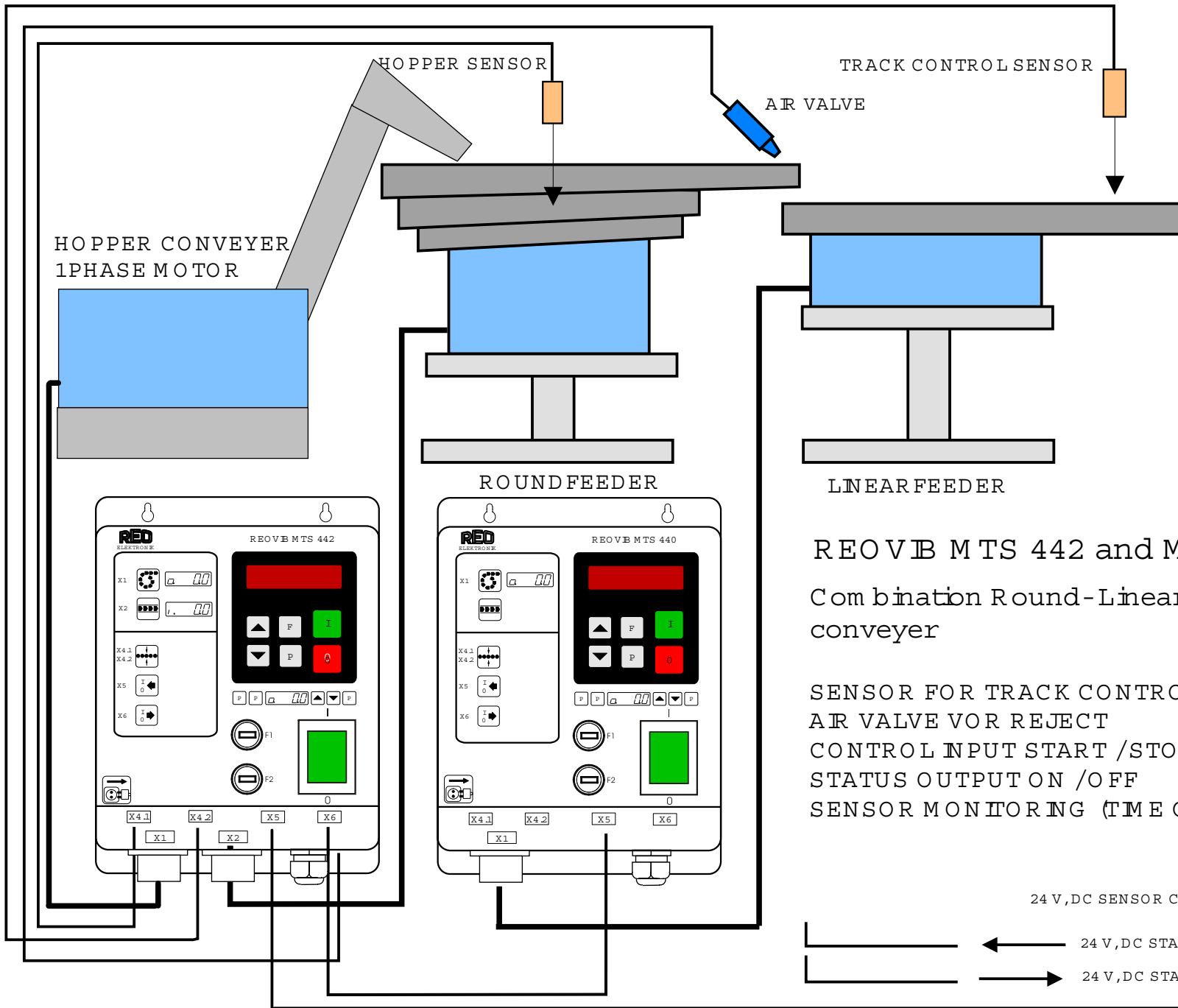

REOVIB MTS 442 and MTS 440

Combination Round-Linearfeeder and Hopper conveyor

- SENSOR FOR TRACK CONTROL ON LINEARFEEDER
- AIR VALVE VOR REJECT
- CONTROL INPUT START /STOP
- STATUS OUTPUT ON /OFF
- SENSOR MONITORING (TIME OUT)

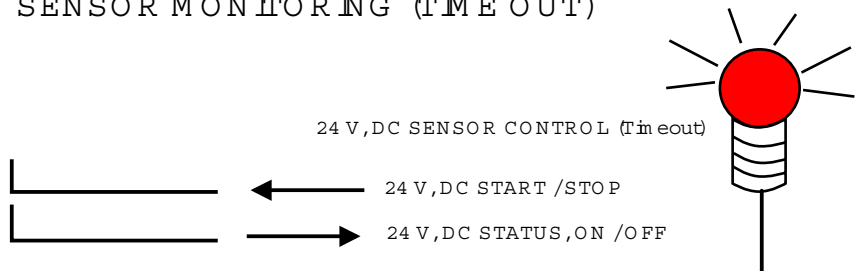

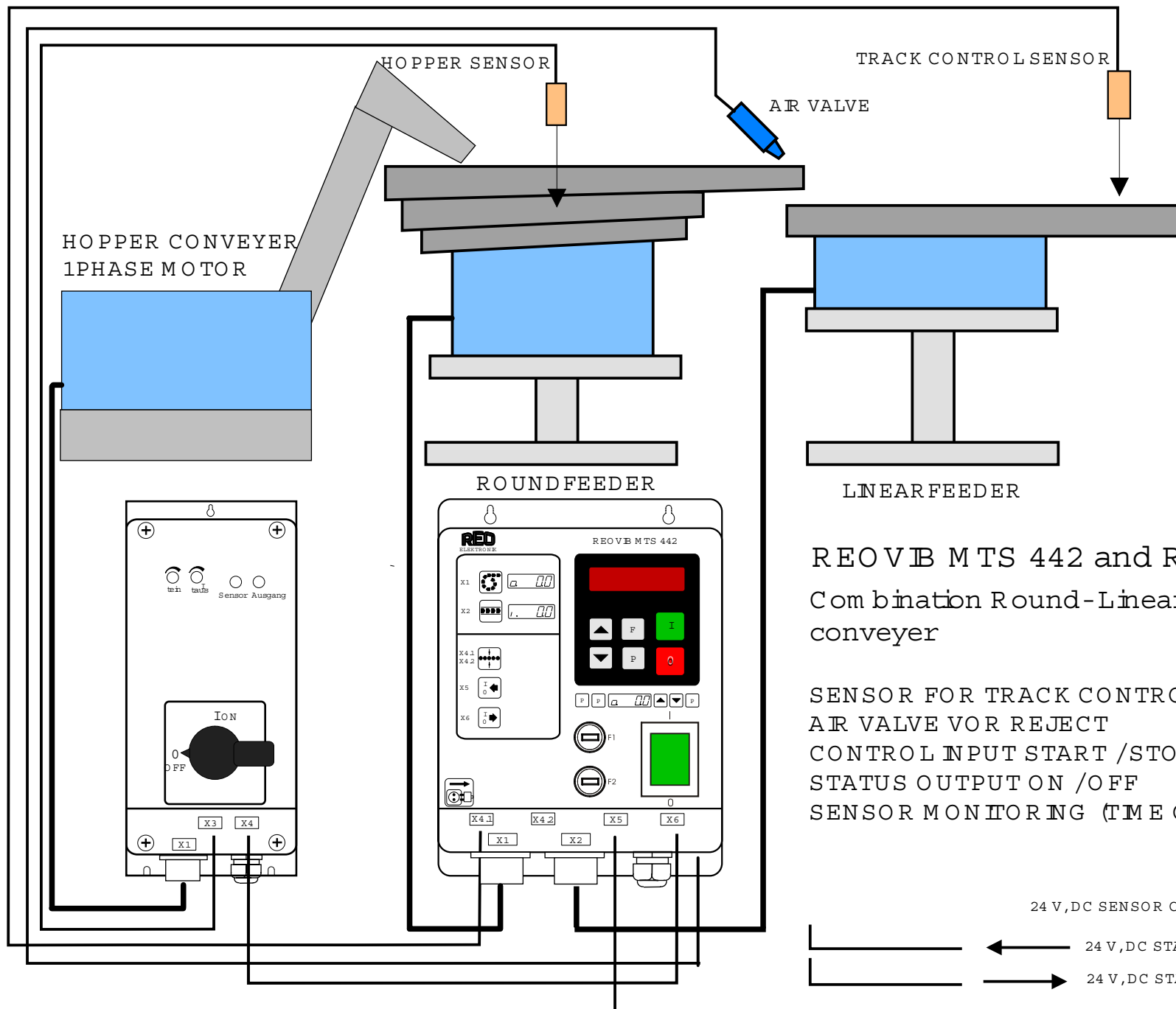

REOVIB MTS 442 and REOVIB 166
Combination Round-Linearfeeder and Hopper
conveyer

SENSOR FOR TRACK CONTROL ON LINEARFEEDER
AIR VALVE FOR REJECT
CONTROL INPUT START /STOP
STATUS OUTPUT ON /OFF
SENSOR MONITORING (TIME OUT)

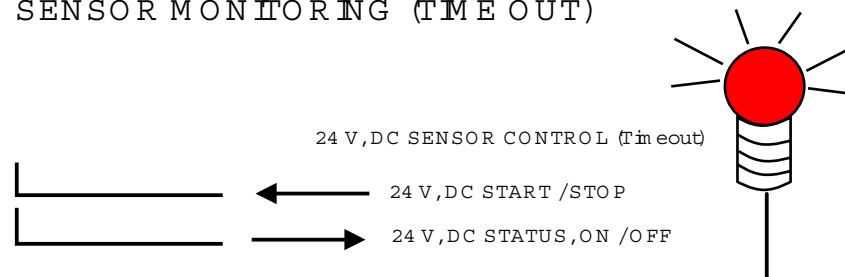

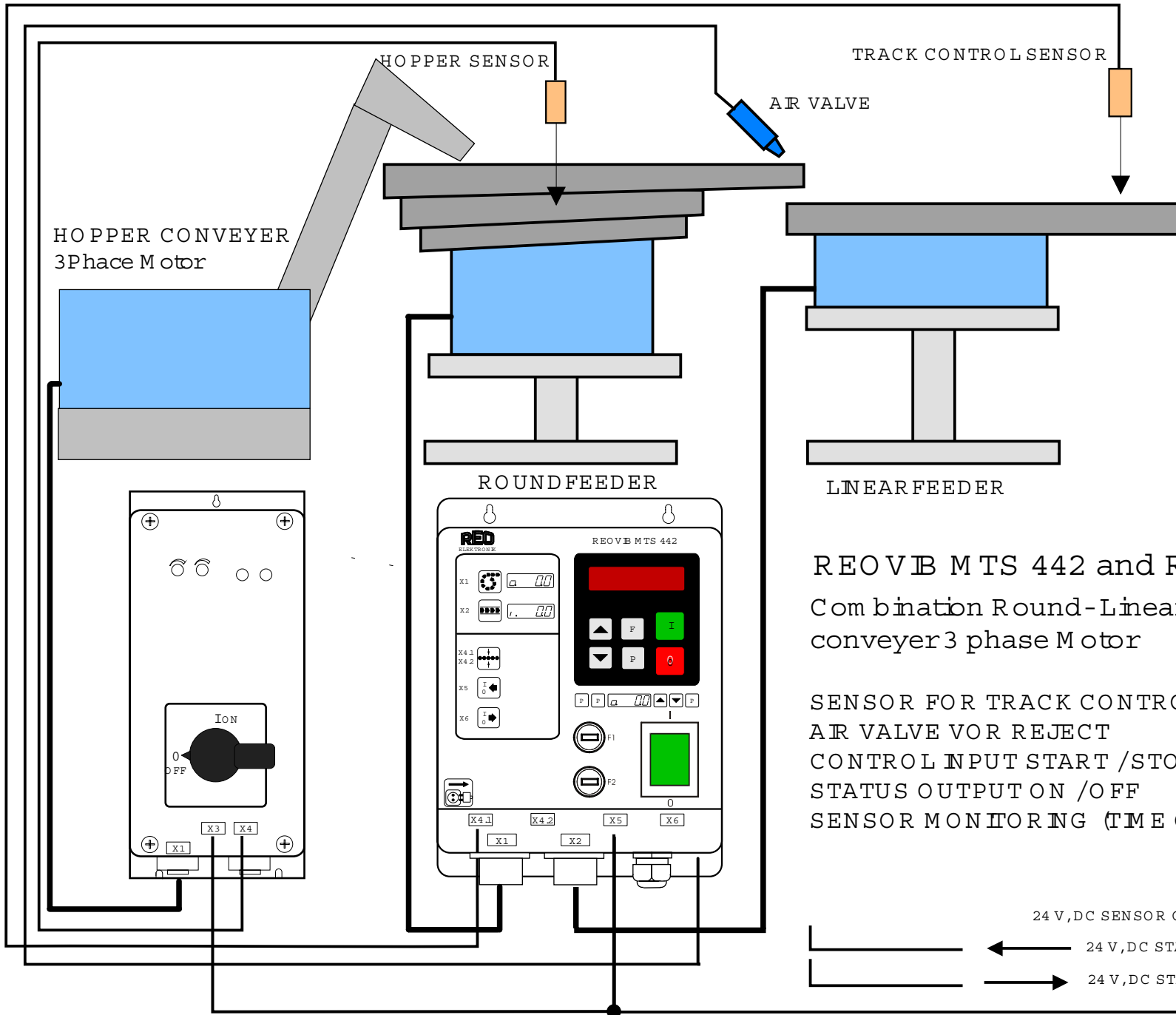

REOVIB MTS 442 and REOVIB 166
 Combination Round-Linearfeeder and Hopper
 conveyer 3 phase Motor

SENSOR FOR TRACK CONTROL ON LINEARFEEDER
 AIR VALVE FOR REJECT
 CONTROL INPUT START /STOP
 STATUS OUTPUT ON /OFF
 SENSOR MONITORING (TIME OUT)

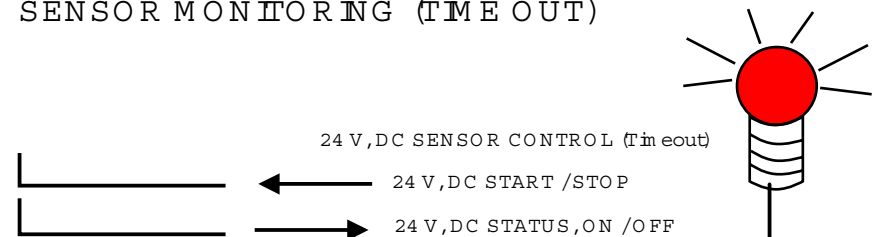

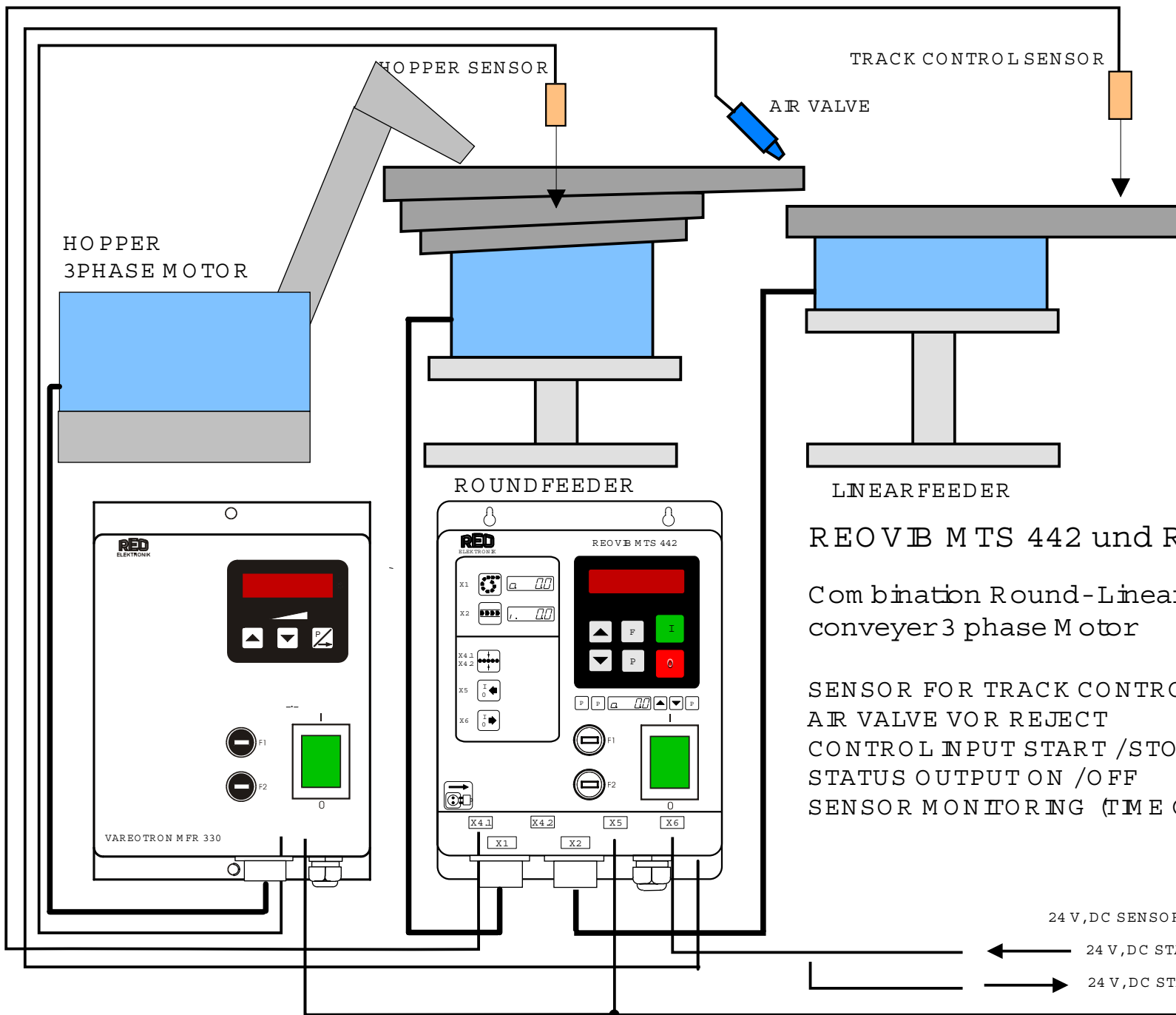

REOVIB MTS 442 und REOVIB MFR 330

Combination Round-Linearfeeder and Hopper conveyor 3 phase Motor

SENSOR FOR TRACK CONTROL ON LINEARFEEDER
 AIR VALVE VOR REJECT
 CONTROL INPUT START /STOP
 STATUS OUTPUT ON /OFF
 SENSOR MONITORING (TIME OUT)

24 V,DC SENSOR CONTROL (Time out)

24 V,DC START /STOP

24 V,DC STATUS,ON /OFF

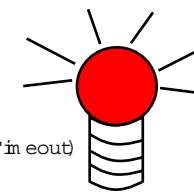

REOVIB MTS 440 und REOVIB MFR 330

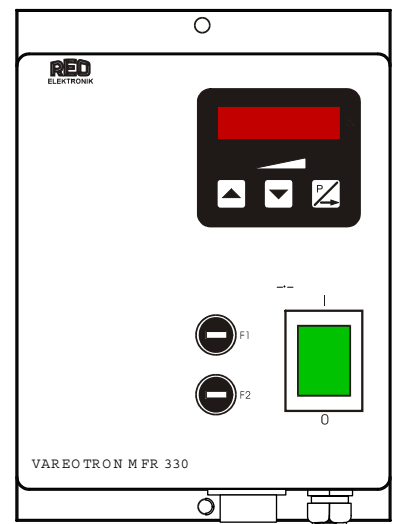
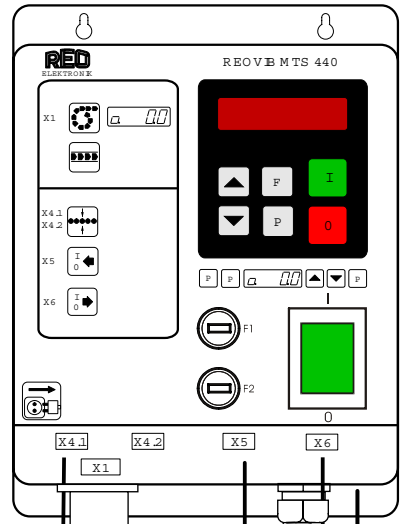
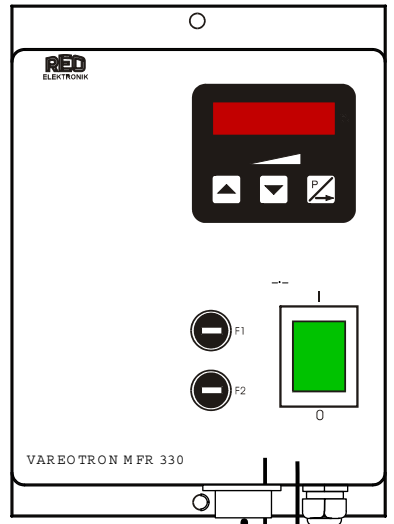
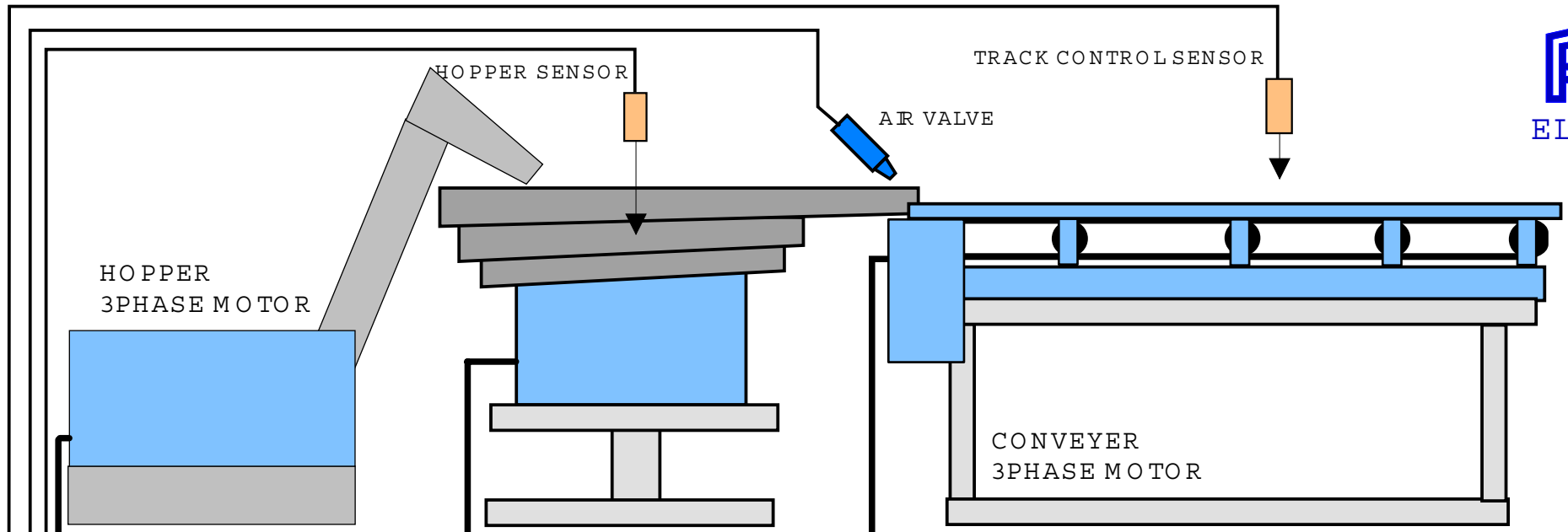

Com bination Roundfeeder, Linear- and Hopperconveyer with 3 phase Motor

- SENSOR FOR TRACK CONTROL ON LINEAR CONVEYER
- AIR VALVE VOR REJECT CONTROL INPUT START /STOP
- STATUS OUTPUT ON /OFF
- SENSOR MONITORING (TIME OUT)

24 V,DC SENSOR CONTROL (Time out)

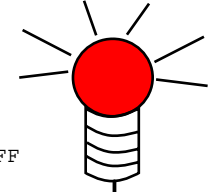

- ← 24 V,DC START /STOP
- 24 V,DC STATUS, ON /OFF

REOVIB MTS 440 und 2x REOVIB 166

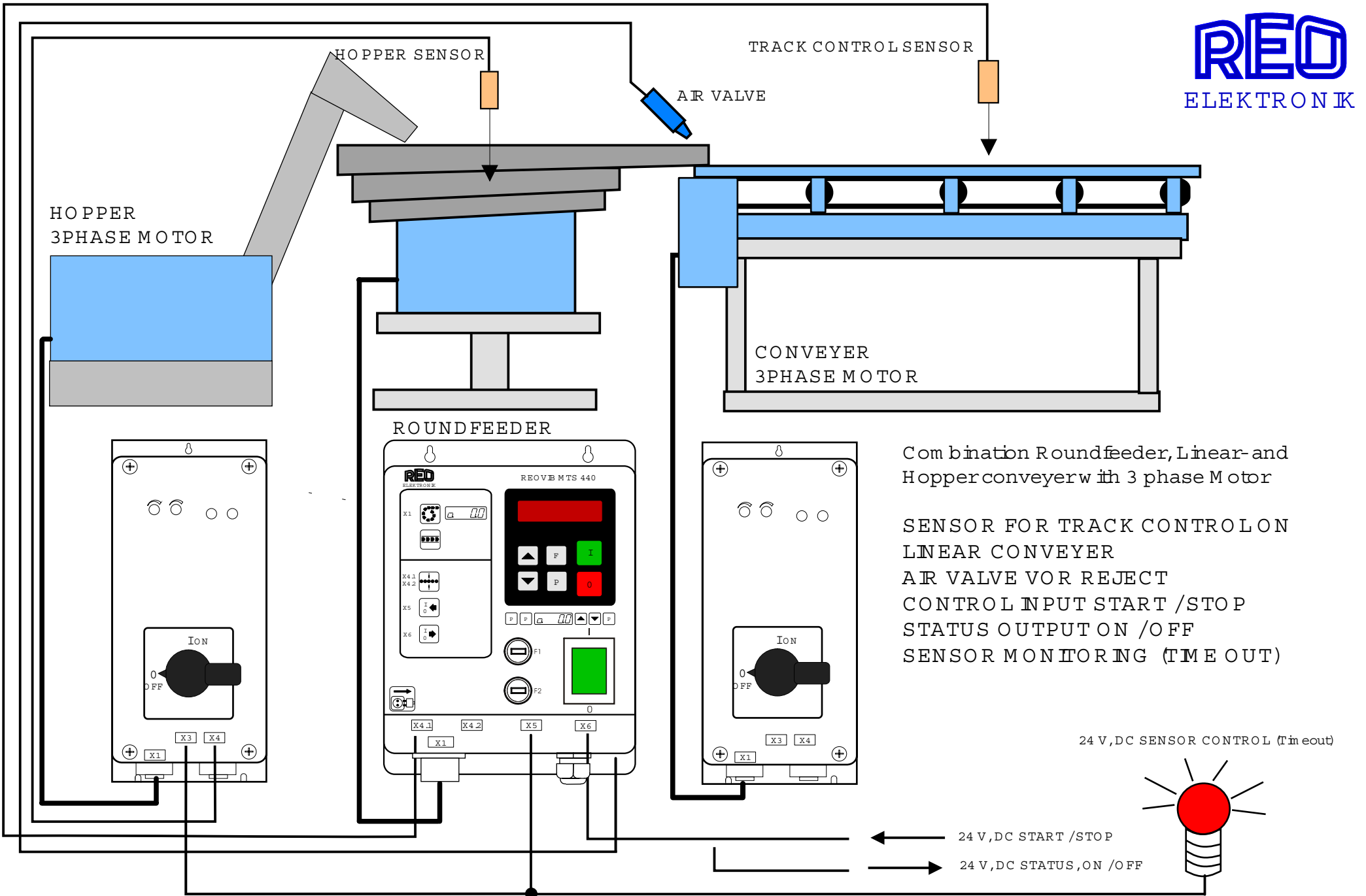

Com bination Roundfeeder, Linear- and Hopperconveyer with 3 phase Motor

- SENSOR FOR TRACK CONTROL ON LINEAR CONVEYER
- AIR VALVE VOR REJECT
- CONTROL INPUT START /STOP
- STATUS OUTPUT ON /OFF
- SENSOR MONITORING (TIME OUT)

24 V,DC SENSOR CONTROL (Time out)

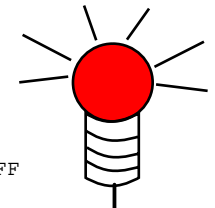

← 24 V,DC START /STOP

→ 24 V,DC STATUS ,ON /OFF

REOVIB MTS 440 und 2x REOVIB 166

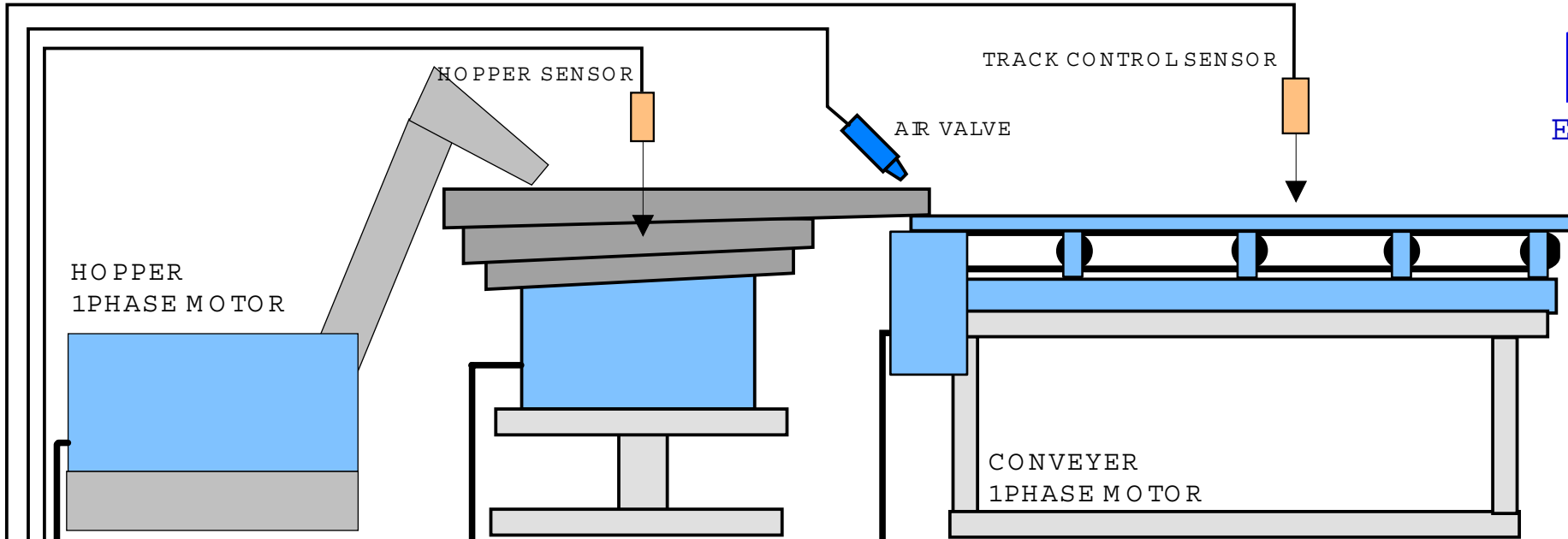

Com bination Roundfeeder, Linear- and Hopperconveyrw ith 1 phase Motor

- SENSOR FOR TRACK CONTROL ON LINEAR CONVEYER
- AIR VALVE VOR REJECT CONTROL INPUT START /STOP
- STATUS OUTPUT ON /OFF
- SENSOR MONITORING (TIME OUT)

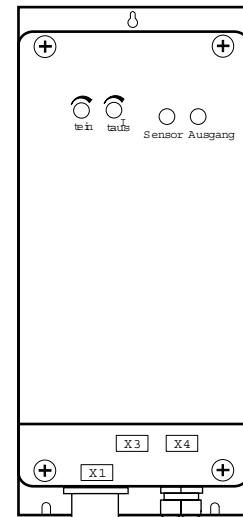
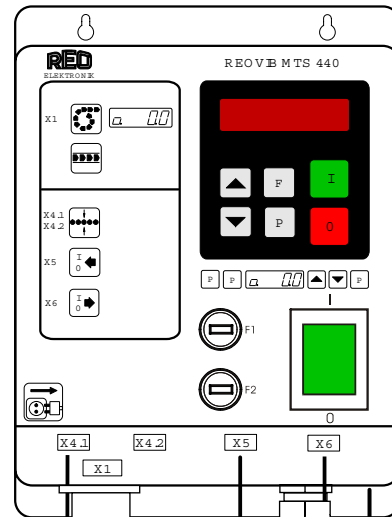
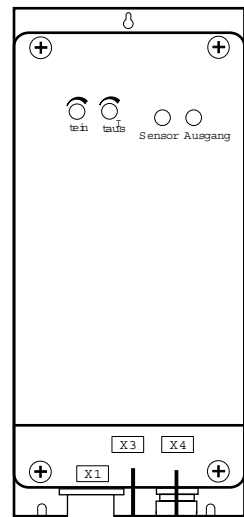

24 V,DC SENSOR CONTROL (Time out)

← 24 V,DC START /STOP

→ 24 V,DC STATUS, ON /OFF

