

Bedienungsanleitung



Electronic control unit for operating material storing hoppers

Control unit for switching of a three phase AC motor in function of a material level. The actual material level is given by a 24 V (PNP) sensor. If the sensor shows material demand (24 V signal) the motor will be switched on after an adjustable time delay (0,1...15 sec). Likewise, if the sensor shows no material demand the motor will be switched off after an adjustable time delay (1,5...15 sec).

An enable input is provided to permit connection with other control units so that the hopper motor will run only if another unit as a part of the whole system is also switched on.

The trimming potentiometers for switch-on and off time delay are adjustable from the front panel upon removal of the blind sealing plug.

The switching status of the sensor and motor output is shown by the LEDs in the front panel.

The unit is provided with a Bi-metal relay with lock to ensure motor protection. In case of motor protection response the motor will switch off permanent and will have to be unlocked manually (hereto it is necessary to remove the front panel).

Technical data



Input voltage (line)	230V (115V), +/- 10%, 50/60Hz
Motor voltage	24V DC
Motor power	40W
Release input	potential Contact or 24V DC
Umgebungstemperatur	0...+ 45°C
Abmessung (L xB x H)	205 x 90 x 100 mm
Protection	IP 54
Sensor input	24VDC, 50mA
On- and off delay time, track control	0,1 ... 15sek.
Timeout	30 ... 240sek

Bedienungsanleitung

Safety Instructions

This description contains the necessary information for the correct application of the product described below. It is intended for use by technically qualified personal.

Qualified personnel are persons who, because of their training, experience and position as well as their knowledge of appropriate standards, regulations, health and safety requirements and working conditions, are authorised to be responsible for the safety of the equipment, at all times, whilst carrying out their normal duties and are therefore aware of, and can report, possible hazards (Definition of qualified employees according to IEC 364)

-  **Warning!**
 Hazardous Voltage
 Failure to observe can kill, cause serious injury or damage
-  Isolate from mains before installation or dismantling work, as well as for fuse changes or post installation modifications.
 Observe the prescribed accident prevention and safety rules for the specific application.
 Before putting into operation check if the rated voltage for the unit conforms with the local supply voltage.
 Emergency stop devices must be provided for all applications. Operation of the emergency stop must inhibit any further uncontrolled operation.
 Electrical connections must be covered
 The earth connection must be checked, for correct function, after installation.

Installation

Check !	Are the supply, feeder coil and controller input voltages correct ? Is the controller adequately rated for the rated power of the feeder ? What is the vibrating frequency of the feeder ?
Connect the unit in accordance with the wiring instructions and ensure that earthing is correct !	

 **To keep the protection of the unit , you must fit in the blankink plug after the adjustment of the trimmer**

Bedienungsanleitung

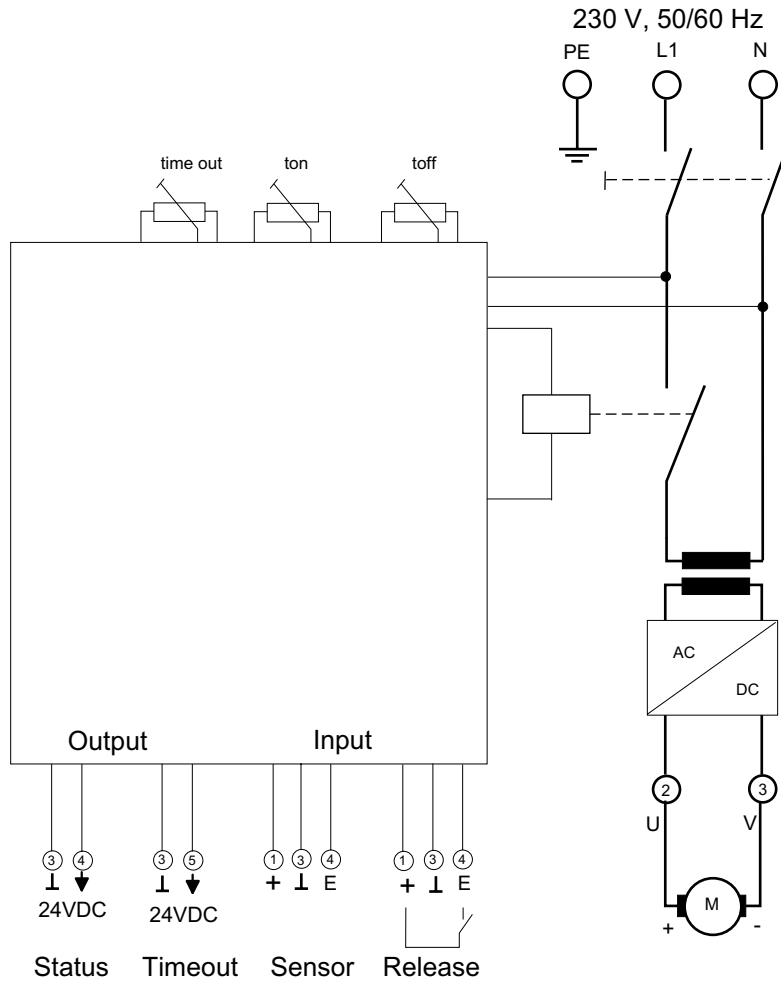

Adjustment of the trimmer "ton" , "toff" and "time out"

Remove the blanking plug in the frontpanele, then adjust the trimmer, with a small screwdriver, to the time witch you need. Turn right- the time goes up..

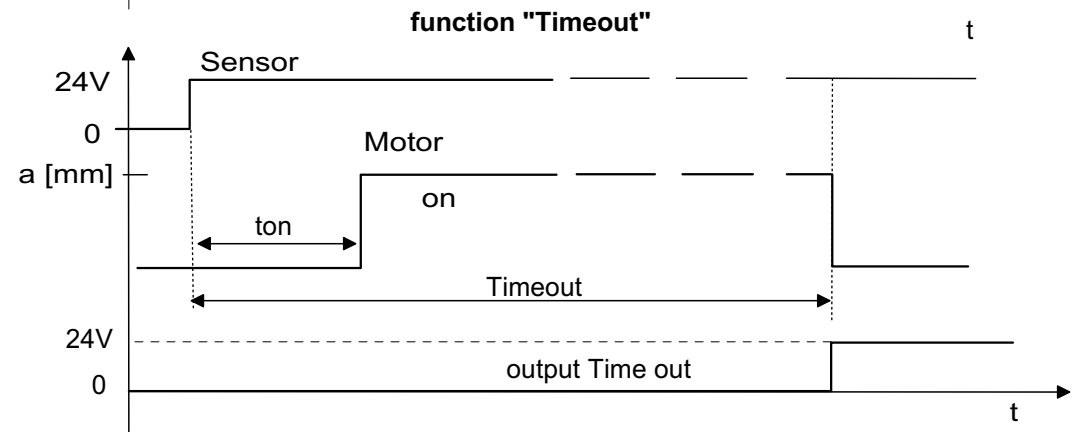
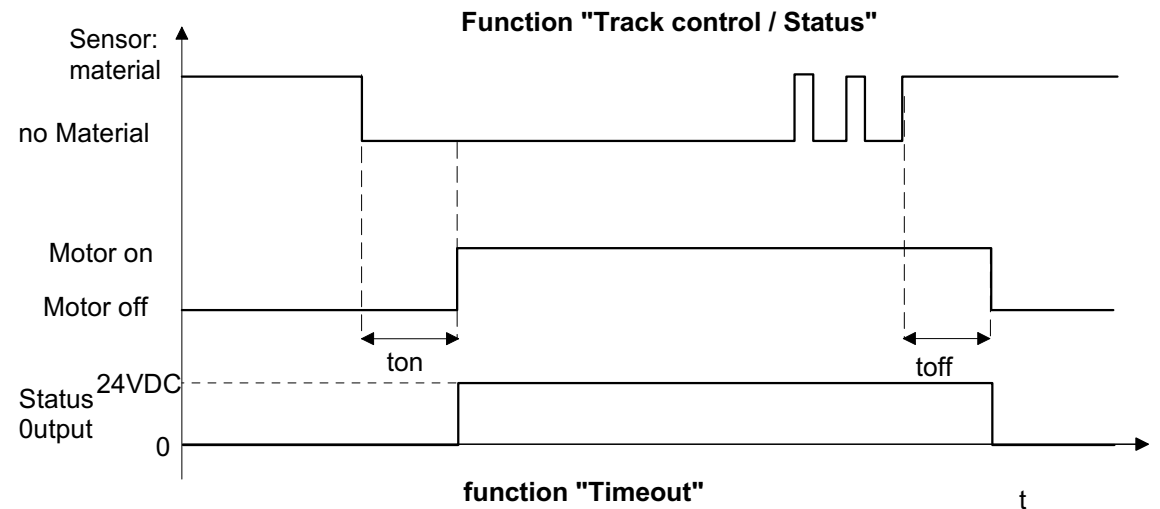

To keep the protection of the unit , you must fit in the blankink plug after the adjustment of the trimmer

Bedienungsanleitung

enclosure demension

plug connection



To keep the protection of the unit , you must fit in the blankink plug after the adjustment of the trimmer

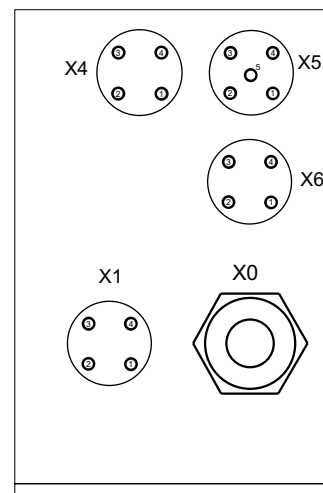
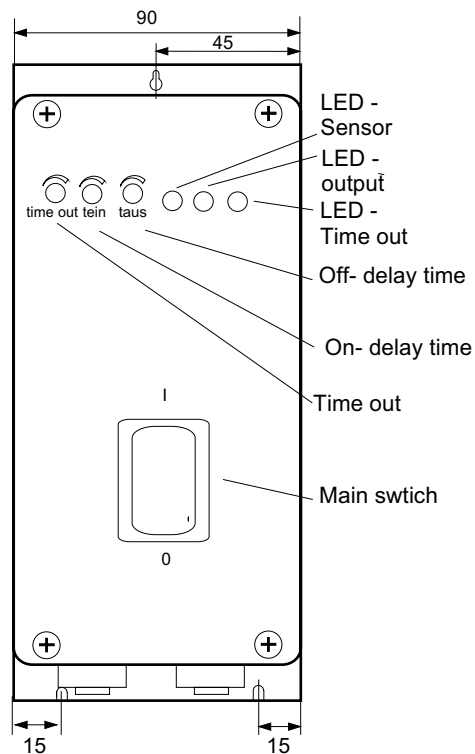
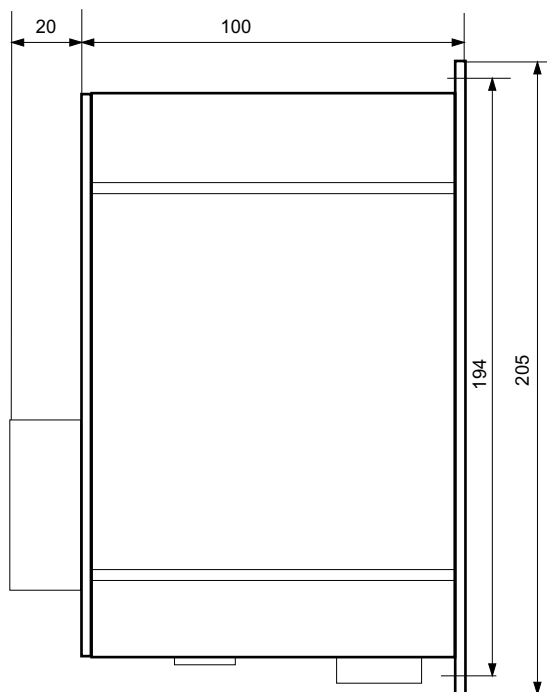

Sensor PNP Sensor (X4)

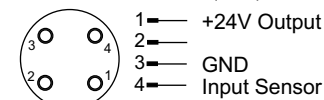

Status output (X5)

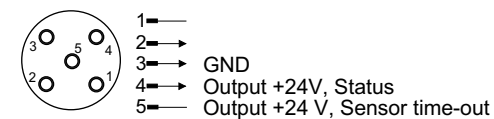

Release (X6)

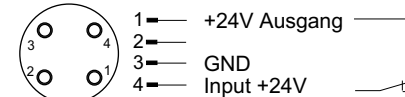

24VDC Motor output (X1)

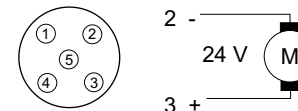

Bedienungsanleitung

Inverting Sensor Change-over Sensor PNP / NPN Change-over function Release / Enable



Connection jumper

Inverting sensor

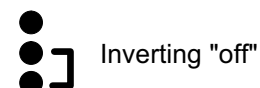

Input sensor

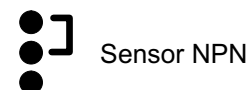
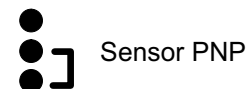

Change-over release / enable

