

Operating Instructions

REOTRON MEW 700

1-Phase-Thyristor Power Controller

Option Profibus-DP

REO ELEKTRONIK AG

Development + Sales
Brühler Strasse 100
D-42657 Solingen
Tel. (0212) 88 04-0
Fax (0212) 88 04-188
www.reo.de
email: sales@reo.de

REOTRON

ELECTRONIC POWER CONTROLLER

Contens

Technical Information for the User	3
1.0 General	4
2.0 Construction.....	4
3.0 Feature	5
3.1 Mode.....	5
3.2 Regulation mode.....	5
3.3 Set point.....	6
3.4 Feedback	6
3.5 Control functions.....	7
3.6 Interface mode (Profibus DP)	8
3.6.1 Bus Operating Mode.....	9
4.0 Technical Data.....	10
4.1 Limited the output voltage by using line input from 230V or 240V	10
5.0 Declaration of Conformity	10
6.0 Ordering codes	10
7.0 Operation	11
7.1 Adjustment	11
7.2 Adjustment Procedure	11
7.3 Indications on display.....	12
7.4 Error Messages.....	12
8.0 Settings.....	13
9.0 Setting up instructions	14
9.1 internal set piont.....	14
9.2 Unit configuration	14
9.2.1 Service	14
9.3 Setting Up Procedures.....	15
9.4 Select Interface	15
9.5 Save current settings	16
9.6 Restore parameter settings.....	16
9.7 Hide parameter menus	16
10.0 Connection diagram	17
10.1 Connection details	18
11.0 Dimensions	19
12.0 Putting into service	21
12.1 Preliminaries	21
12.2 Measurements and Settings	21
12.3 Putting into service without a proper load.....	21
13.0 Installation of Thyristor Control Units.....	22
13.1 Fuses	22
13.2 Incoming breaker	22
13.3 Output Breaker.....	22
13.4 Installation and climatic Conditions.....	22
13.5 Signal cables.....	22
14.0 Interference prevention.....	23
14.1 Earthing.....	23
14.2 Control cables	23
14.3 Interference protection of other external components and equipment	23
Annex Profibus-DP	24
Programming for Bus operation.....	25
Parameter Table	28
Example of bus communication	29
Normal mode.....	29
Parameter Operation.....	29
RESET Controller.....	30

Technical Information for the User

This description contains the necessary information for the correct application of the product described below. It is intended for use by technically qualified personal.

Qualified personnel are persons who, because of their training, experience and position as well as their knowledge of appropriate standards, regulations, health and safety requirements and working conditions, are authorised to be responsible for the safety of the equipment, at all times, whilst carrying out their normal duties and are therefore aware of, and can report, possible hazards (Definition of specialist according to IEC 364).

Safety Instructions

The following instructions are provided for the personal safety of operators and also for the protection of the described product and connected equipment.



Warning!

Hazardous Voltage

Failure to observe can kill, cause serious injury or damage

- **Isolate from mains before installation or dismantling work, as well as for fuse changes or post installation modifications.**
- **Observe the prescribed accident prevention and safety rules for the specific application.**
- **Before putting into operation check if the rated voltage for the unit conforms with the local supply voltage.**
- **Emergency stop devices must be provided for all applications. Operation of the emergency stop must inhibit any further uncontrolled operation.**
- **Electrical connections must be covered**
- **Earth bonding must be tested prior to operation**

Prescribed Use

The units described herein are electrically powered for use in industrial applications. They are designed for power adjustment of resistive or inductive loads

1.0 General

The range of REOTRON MEW Thyristor Regulators are microprocessor based units for controlling the power to resistive and inductive loads. In essence the units comprise inverse parallel connected power semiconductors (thyristors) and the control and regulation electronics. The units have a regulated, AC output. The inverse parallel connected thyristors operate as contact free, power controllers using the phase angle control or the full wave principles. In the phase angle control mode the equipment can be used as a voltage or current regulator and also there is an option for power regulation. The set point value for the current and voltage can be provided by an external control voltage of 0-10 V, 0(4)-20 mA, DC or a potentiometer. The lowest set point has priority. The effective value is fed back internally from a voltage or current transformer. The maximum current limit of the unit cannot be exceeded in all regulation modes, using phase angle control. Applications with a wide load resistance variation R_{cold}/R_{warm} are possible, and an overloading of the unit is prevented.

Typical Applications

Industrial Ovens
Infra Red Emitters (Dryers)
Tunnel Heaters
Plastic Moulding Equipment

Steam Generators
Preheating Plants
Room Heating Equipment
Extruders

Lighting Installations
Air Conditioning Plant
Fan Heating Systems

2.0 Construction

The REOTRON -MEW 700 thyristor controller is a completely functional, compact, unit. It has been designed for building into an enclosure. All connections for the supply, power output, feedback signals and the supply for the isolator are made through screw terminals. A touch panel with an LED display and setting up keys is incorporated in the front panel. There are connectors provided for analogue signals and optional a field bus interface. Inside the unit there is a printed circuit, control card and a power card, comprising the semiconductors, firing and regulating circuits and the system power supply.

Overview

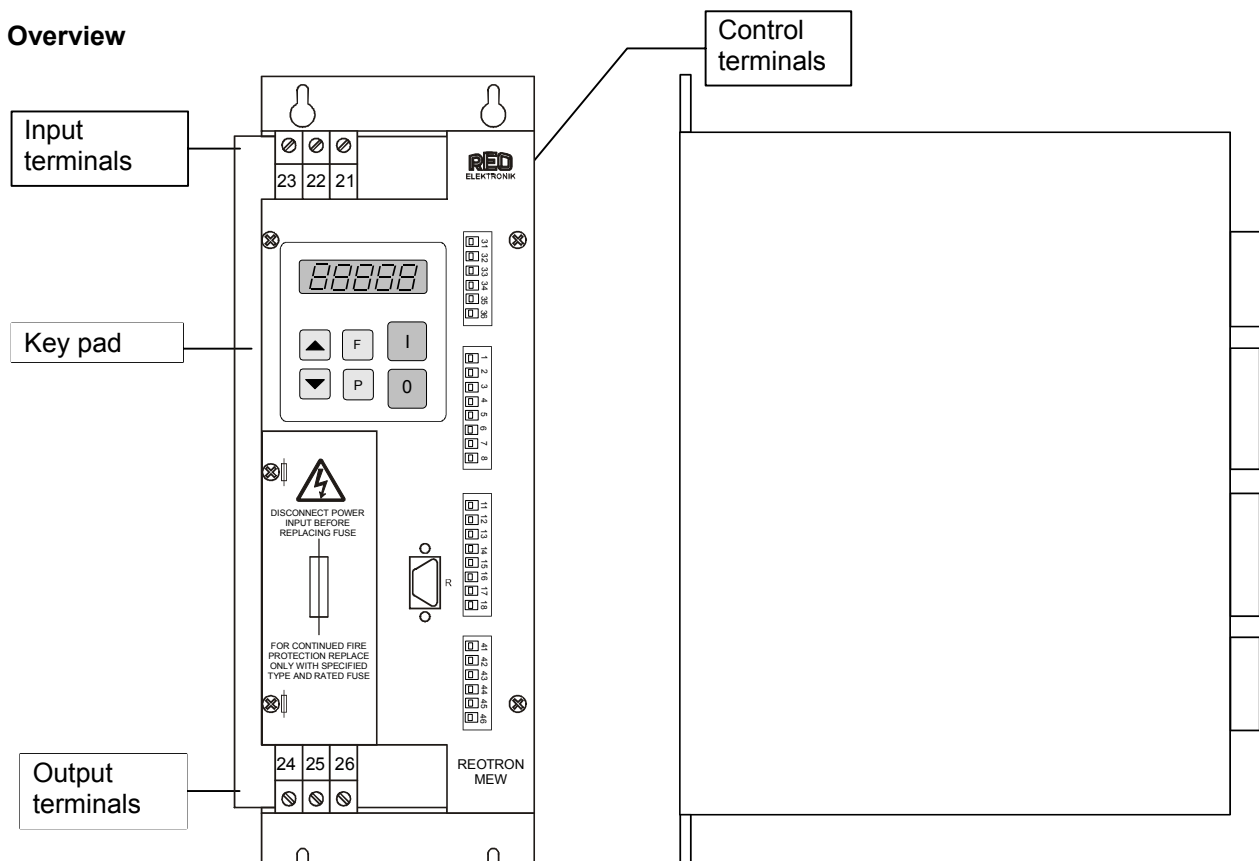

3.0 Feature

Mode:		
1.	Phase angle control	
2.	Full wave principle	
Regulation mode:		
1.	Current regulation	RMS
2.	Voltage regulation	RMS
3.	Power regulation	Real power
Set point inputs:		
1.	Voltage or Power	Potentiometer 10 kR, 0...+10 V, 0(4)...20 mA, internal Keypad
2.	Current	Potentiometer 10 kR, 0...+10 V, 0(4)...20 mA, internal Keypad
	Option Serial interface	Set point via serial interface
Feedback monitoring:		
1.	Voltage or Power	Voltage 0...+10 V, DC correspond 0...100% RMS
2.	Current	Current 0...+10 V, DC correspond 0...100% RMS
Status		
	Enable (ON/OFF)	Contact or 24 V, DC
	Fault relay	Change over contact
Interface: Option		
	Serial	RS 232
	Fieldbus	INTERBUS-S, Profibus-DP

3.1 Mode

Phase angle control

In the phase angle control mode the mains voltage half waves are more or less cut in function of the given set point.

This mode of operation is suitable for resistive, inductive and resistive-inductive loads.

The benefits with this mode of operation are the continuous adjustment, the fine dosing and the high regulating dynamics. A dynamic current limitation is possible only with this mode of operation.

Full wave control

In the full wave principle mode of operation, always full sinus waves are switched in function of the set point. In this operating mode almost no harmonics are produced, however, the dynamic regulation is not possible. This mode of operation is suitable in particular for loads with high thermal inertia.

3.2 Regulation mode

The REOTRON MEW Thyristor Regulator range include 3 regulators, ie. voltage, current and power regulator. All the regulators always work in combination, ie. with voltage regulation for example, the current regulation operates like a cascade control and limits the output current in case of overload on the rated current. In case of current regulation mode, the maximum voltage limit can be prescribed over the voltage set point. With power regulation, the current limit is also effective as cascade.

In case both the voltage and current regulation are used, the set point of the power regulator must be set to 100 % (over display, in menu „C 002“, parameter „P“).

Voltage regulation

Microprocessor controller with PI Characteristics; the P portion is adjustable externally by using the keypad. The units maximum voltage output is factory set to the rated voltage (for 100% set point).

Parameter setting

Parameter	Code	Setting
Ausgangsleistung „P.“	C 020	100%
Set point current „I.“ Display or Set point current connection 7 u. 8	C 020	100%, or smaller bridge = 100%

Current regulation

Microprocessor controller with PI Characteristics; the P portion is adjustable externally by using the Key-Pad. The units maximum output current (Rated Current) is factory set.

Parameter setting

Parameter	Code	Settings
Output power „P.“	C 020	100%
Set point voltage „U.“ Display or Set point current connection 3 u. 4	C 020	100%, or smaller bridge = 100%

Power regulation

With power regulation, the real power value is controlled. In this case, the input that is normally coordinated to the voltage set point is now used as set point input. This set point input corresponds to 0...100 % of the unit output power.

The current set point must be set to 100 % or to the required limit value. Setting over display or link between terminals 7 and 8.

Parameter setting

Parameter	Code	Settings
Output power „P.“	C 020	0%
Set point voltage „U.“ Display	C 020	100%, or smaller
Set point voltage „I.“ Display or Set point current connection 7 u. 8	C 020	100%, or smaller bridge = 100%
Power regulation „E.F.P.“	C 003	1

3.3 Set point

Two Inputs for external signals

Setpoint Input U, P 0-10V DC, 0(4)...20 mA or Potentiometer 10kΩ

Setpoint Input I 0-10V DC, 0(4)...20 mA or Potentiometer 10kΩ

3.4 Feedback

Current feedback

The current is measured, in one phase, with an internal current transformer. The internal microprocessor determines the effective value of the output current and makes adjustments through a PI loop.

Voltage feedback

The effective voltage is measured with an internal Transformer. It is converted in an analogue input stage and then fed to the internal microprocessor. The effective value is thus determined and applied used for PI regulation using software.

Output monitor

Effective Voltage 0...10 V; DC correspond 0...100 % output voltage or output power.

Effective Current 0... 10 V; DC correspond 0...100 % output current

3.5 Control functions

Enable

Run / Stop input.

A control voltage (24V DC) must be applied to terminals 32(+) and 31(-), to enable the unit, or a connection made between terminals 32 and 33 by using a switch. A permanent link between terminals 32 and 33 is used for operation without an external enable. The firing pulses are inhibited whilst the enable input is not closed.

Start ramp / Stop ramp

This function reduces surges on the mains supply when the load is switched on and off.

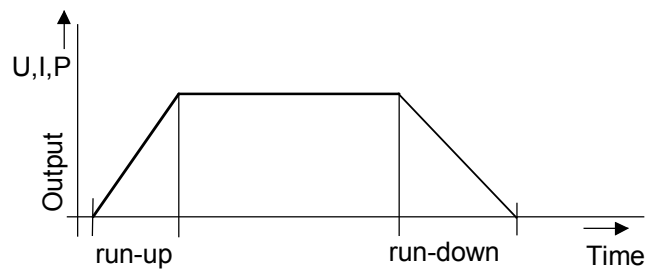

Set point control (min / max)

The set-point control characteristics can be adjusted to match the subsequent process controller or automation system, by setting the lower and upper values

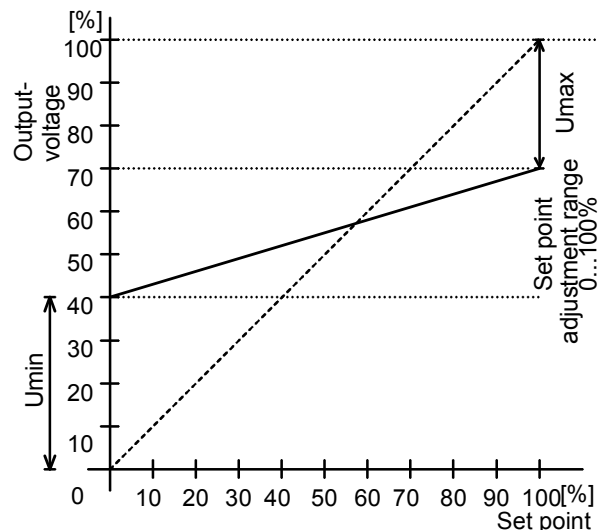

Status / Ready relay (clamp 41,42,43)

For monitoring the actual status, an internal relay can be used. In case of applied input voltage and enabled power output, clamp 42 – 43 closes.

For using this relay as a “READY” signal point “r.b.” in Code “C 003” has to be set to 1. In case of an error like “LO.PO.”, clamp 42 – 43 opens.

Clamp assignment:

- 41 → normally close
- 42 → change-over contact
- 43 → normally open

Failure relay (clamp 44,45,46)

In case of an error (for example “Error Hot”) the contact 45 – 46 closes.

Clamp assignment:

- 44 → normally close
- 45 → change-over contact
- 46 → normally open

3.6 Interface mode (Profibus DP)

The interface provides communication with the control unit 3 data words (each using 16 bits) The three 16 bit words are sent and feedback received for each bus cycle. The following settings can be sent to the controller.

Voltage / Power Setpoint (16 bit)	Word 1
Current Setpoint (16 bit)	Word 2
Control Command ON/OFF	Word 3

Feedback from control unit

Actual Voltage / Power (16 bit)	Word 1
Actual Current (16 bit)	Word 2
Status and Fault Warning	Word 3

Important! Data consistency is required to operate with Profibus Master

For example, Data consistency is defined in a Siemens S7 PLC with SFC14 and SFC15.

Note

Units are factory set for analogue operation, parameter SIF in Menu C017 must be set to `1` for bus operation.

Technical Data for Profibus Interface

Bus Power Supply	24 V, DC (20..30 V), 200 mA
Bus connector	DB 9
Internal interface	Serial, RS 232 TTL-level
Supported baud rates	9,6 / 19,2 / 93,7 / 187,5 / 500 / 1,5 / 3 / 6 /12 Mbaud (REOX6662.GSD)
Communication	Data consistency
Protocol	DP

GSD-File

The following GSD file is required for Profibus interfacing

GSD File Name	REOX6662.GSD
---------------	--------------

The GSD file is supplied on 3.5" Floppy disk with each unit or alternatively, visit www.reo.de to download the file from the REO website

3.6.1 Bus Operating Mode

Two fundamental operating modes can be chosen for bus communication.

Normal Operation: Control of the thyristor regulator in production, in which case the Setpoint and ON/OFF control signals are transmitted

Parameter Operation: Adjustment of the thyristor regulator for the desired operation mode and limits.
In a special mode the parameter and parameter addresses are transmitted and acknowledged.
In parameter operation, the units specific values, such as soft start time, timers and switching etc, are set.

Addressing

The DIP switches in the front panel must be set to give the address of each unit, when the Profibus is used.

The bus address setting is made using the DIP switches in the front panel. Addresses are in HEX	1	Address bit 0
	2	Address bit 1
	3	Address bit 2
	4	Address bit 3
	5	Address bit 4
	6	Address bit 5
	7	Address bit 6
	8	Reserved

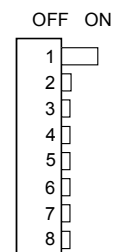

In normal mode the set points (for example voltage and current) and the digital control signals are sent to the controller, also the actual values (for example voltage and current) and the controller status are sent from the controller over the Profibus.

All data words have the value 0...65535. To recognize an overrun on the output the feedback value is designed from 0..65535 → 0..200%.

Set point:	0...100 %	0...65535
Actual value:	0...200 %	0...65535
	0...100 %	0...32768 (Voltage / current feedback, without sign)
	0...100 %	0...16384 (Power feedback, with sign)

4.0 Technical Data

Type	Input voltage [V]	Output voltage [V]	Output current[A]
MEW 700-25/230 - 400	230 - 400V +/- 10% 50/60 Hz	Ue – 3 V	0...25
MEW 700-50/230 - 400			0...50
MEW 700-80/230 - 400			0...80
MEW 700-110/230 - 400			0...110
MEW 700-200/230 - 400			0...200
MEW 700-300/230 - 400			0...300
Load	R / RL, Transformer Load max. Induction 1,45 Tesla		
Set point Inputs	0...+10 V	22 kR	
current	0(4)...20 mA	100 R	
voltage or power	Potentiometer 10 KR, internal Display		
External feedback U	0...+/-5 V	22 kR	
External feedback I	0...+/-5 V	22 kR	
Feedback monitor	0...+10 V, DC	5 mA	
U or P			
Feedback monitor I	0...+10 V, DC	5 mA	
Enable	Contact	5 mA	
	24 V, DC	5 mA	
Faulty relay	Change over contact 250 V, 1 A		
Protection	IP 20		
Operating temperature	0...+45 °C		
Storing temperature	-20...+75 °C		
Rel. air humidity	93 % without condensation and surface water coning		
Contamination level	degree 1 (IEC 664)		
Mounting direction	Vertical (Connections below)		
Mounting height	1000 m, 0,5 % rated current reduction for each additional 100 m		
Standards			

4.1 Limited the output voltage by using line input from 230V or 240V

By using the controller at line input from 230 or 240V you must limited the output voltage under Code 020 – point „u“. At line= 230V to 57% and at line= 240V to 60%.

5.0 Declaration of Conformity

In order to comply with the EMC requirements, when using phase angle controllers it is necessary to build in a suitable filter in the line input, e.g. Book-style filter CNW 202.

6.0 Ordering codes

	Input voltage [V]	Output current [A]
REOTRON MEW 700-25/230 - 400	230 - 400	25
REOTRON MEW 700-50/230 – 400	230 - 400	50
REOTRON MEW 700-80/230 - 400	230 - 400	80
REOTRON MEW 700-110/230 - 400	230 - 400	110
REOTRON MEW 700-200/230 - 400	230 - 400	200
REOTRON MEW 700-300/230 - 400	230 - 400	300

7.0 Operation

The six buttons and a LED display found in the front panel, are used for operating and setting up the unit. All operating methods and adjustable parameters can be set up through this panel.

The “I” and “O” buttons are used for switching the unit ON and OFF, however, these do not provide mains isolation, they simply inhibit the power semiconductors

The “P”, “F” and “Cursor Buttons” are used for parameter adjustment. Parameters are set by using menu controls which are called up by entering operator codes. A capital letter is used to indicate the selected function.

The display value can be increased or decreased by units, or tenths of units, by a short press of the cursor buttons. Holding the buttons down will cause the display to change in units of ten.

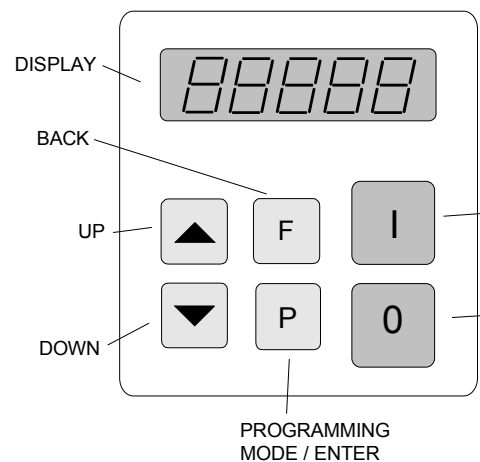

7.1 Adjustment

To prevent accidental or unauthorized adjustment the adjustment parameters, in the user menus, are protected. A code must be entered to open the user menus. There are different pass codes for each function group.

Setting adjustments are automatically saved upon leaving the programming mode or if no button is pressed for a period of 100 seconds.

7.2 Adjustment Procedure

All setting routines are commenced by pressing the programming button “P”. The following diagram should clarify the sequence in which keys are pressed:-

Example

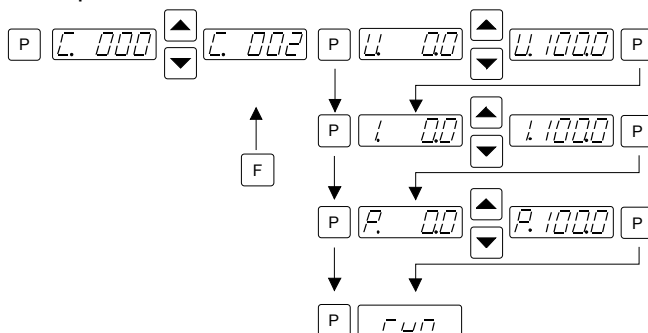



1. Press the “P” key.
2. Select the code number with the cursor keys.
3. Press the “P” key. This displays the first menu point. The required menu point can be found by repeatedly pressing the “P” key (scrolling).
4. The value in the menu point can be changed with the cursor keys.
5. Scroll to the next menu point or to the end of the menu, which returns the display to the set point value, by pressing the “P” key. To exit the menu and return back to the normal display quickly, depress the “P” key for 5 seconds.
6. To return back to the previous position in the menu, press the “F” key

7.3 Indications on display

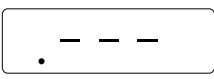
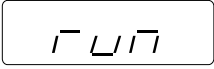
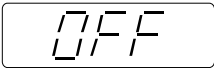
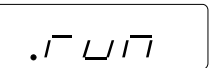
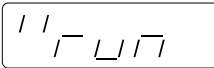
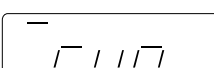
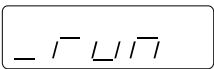
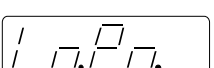
During normal running mode 'run' is shown in the LED display.
In the programming mode an abbreviation for the corresponding parameter (see setting up instructions) and the setting values, are displayed. Setting changes are stored upon leaving the programming mode or after a pause of 100 seconds.

	Initialisation Phase. When the supply voltage is connected (Left decimal point blinks)
	Normal Operation
	Unit is not enabled
	Left decimal point is present. Current regulation is active. The maximum current of the unit or the regulated current setpoint value has been reached.
	The two upper vertical segments of the first digit illuminate. Peak value limiter. This is caused by a fault condition on either the load or by the externally generated effective value, feedback signal. The load impedance is too low, for example, or the effective value is too high.
	The upper horizontal segment of the first digit illuminates. Maximum control limit of the controller has been reached. The unit has no more regulation range available and so the output voltage is near to the supply voltage.
	Lower horizontal of the first digit illuminates. Maximum power limit has been reached
	Under Voltage, input voltage to too low.

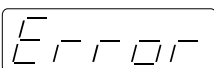
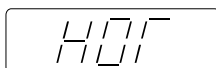
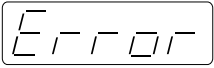
7.4 Error Messages

		Overtemperature of the power semi-conductors, output is inhibited. Use 'C009' to reset
		Overvoltage, input voltage too high, output is inhibited. Use 'C009' to reset

Error messages must be reset in menu 'C009'

8.0 Settings

The following table contains all the available key settable parameters.

The unit is supplied with factory settings that can be recalled from access code "C210" under FAC. User codes can be saved under code "C143" and then recalled with code "C210" under USPA.

Table 1

Parameter:		Code	Factory Default	Menu Code
Setpoint – when internal setpoint is selected only!				
• Voltage set point	0...100 %	U.	0 %	002
• Current set point	0...100 %	I.	0 %	002
• Power set point	0...100 %	P.	100 %	002
Configuration				
• External set point OFF	0 / 1	E.S.O	0	003
• 4...20 mA (only when E.S.P. = I)	0 / 1	4.20	0	003
• Enable Inverse	0 / 1	-En.	0	003
• External Voltage set point	0 / 1	E.F.U.	0	003
• External Current set point	0 / 1	E.F.I.	0	003
• Full wave control	0 / 1	F.S.P	0	003
• Ready relay	0 / 1	r.b	0	003
Parameter				
• Minimum Output Voltage (without set point)	0...100 %	U.	0 %	020
• Minimum Output Current (without set point)	0...100 %	I.	0 %	020
• Minimum Output Power (without set point)	0...100 %	P.	100 %	020
• Maximum Output Voltage (Limit)	25...100 %	<u>u</u>	100 %	020
• Maximum Output Current (Limit)	25...100 %	<u>i</u>	100 %	020
• Maximum Output Power (Limit)	25...100 %	<u>p</u>	100 %	020
• Voltage Regulator – P Characteristic	1...100	P.U.	20	020
• Current Regulator - P Characteristic	1...100	P.I.	15	020
• Power Regulator - P Characteristic	1...100	P.P.	15	020
• Soft Start (ramp)	0...60 Sec.	/.	0,1	020
• Soft Stop (ramp)	0...60 Sec.	\	0,1	020
Interface				
• Serial Interface ON	0 / 1	S.I.F.	0	017
Service				
• Save User Parameter		PUSH		143
• Restore Factory Default Settings		FAC.		210
• Display software version				001

9.0 Setting up instructions

9.1 internal set point

Code C 002

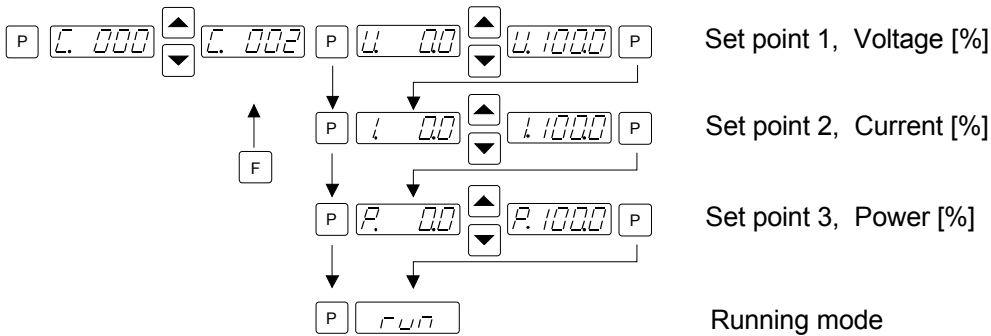

9.2 Unit configuration

Code 003

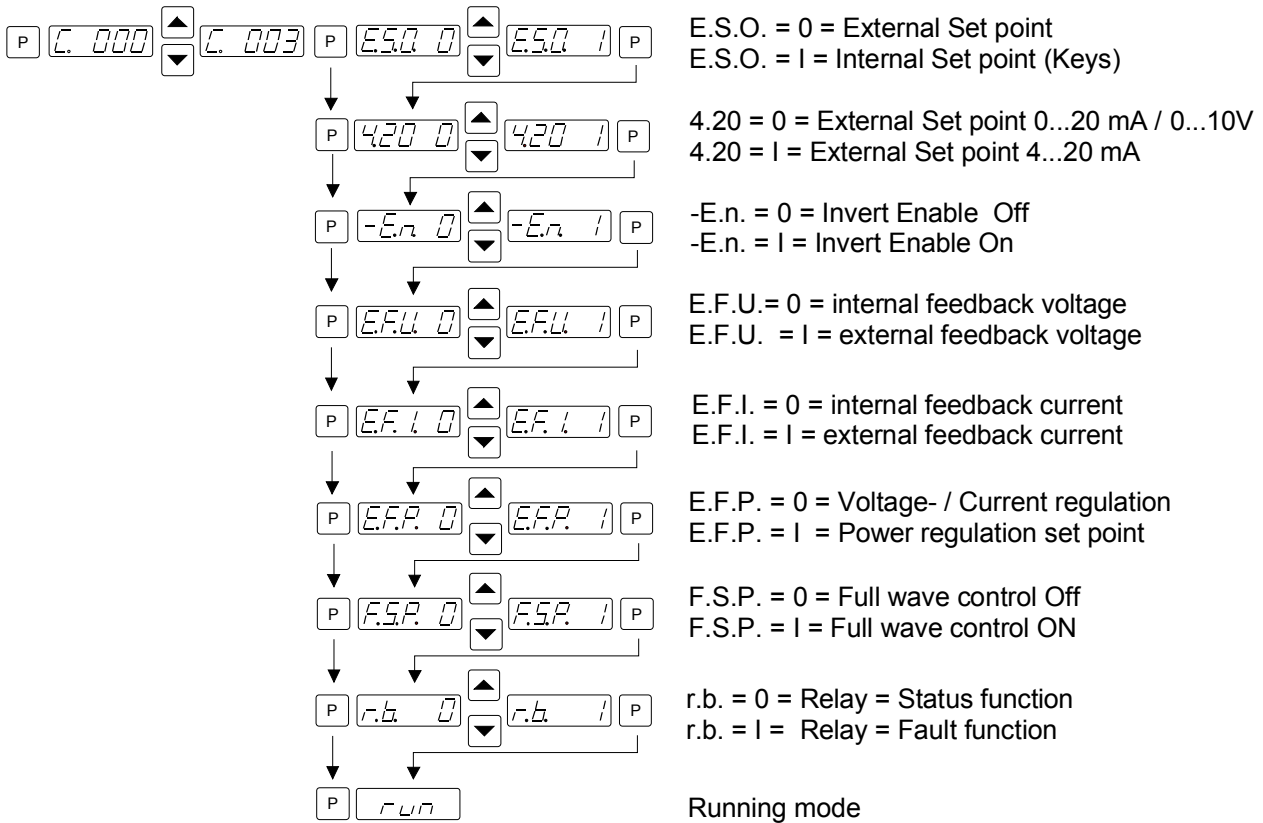

9.2.1 Service

Display only, set point.

Code C 050

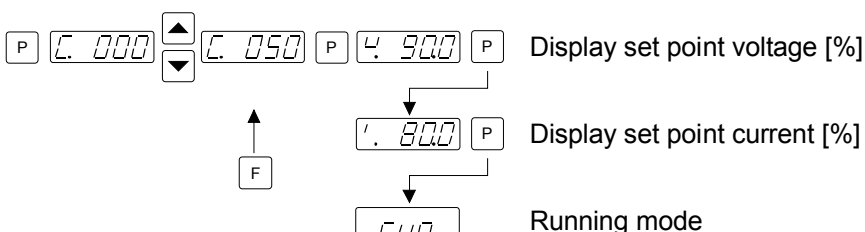

Display only, feedback.

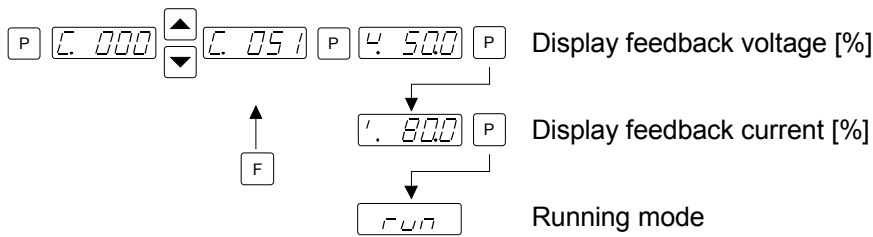

9.3 Setting Up Procedures

Code 020

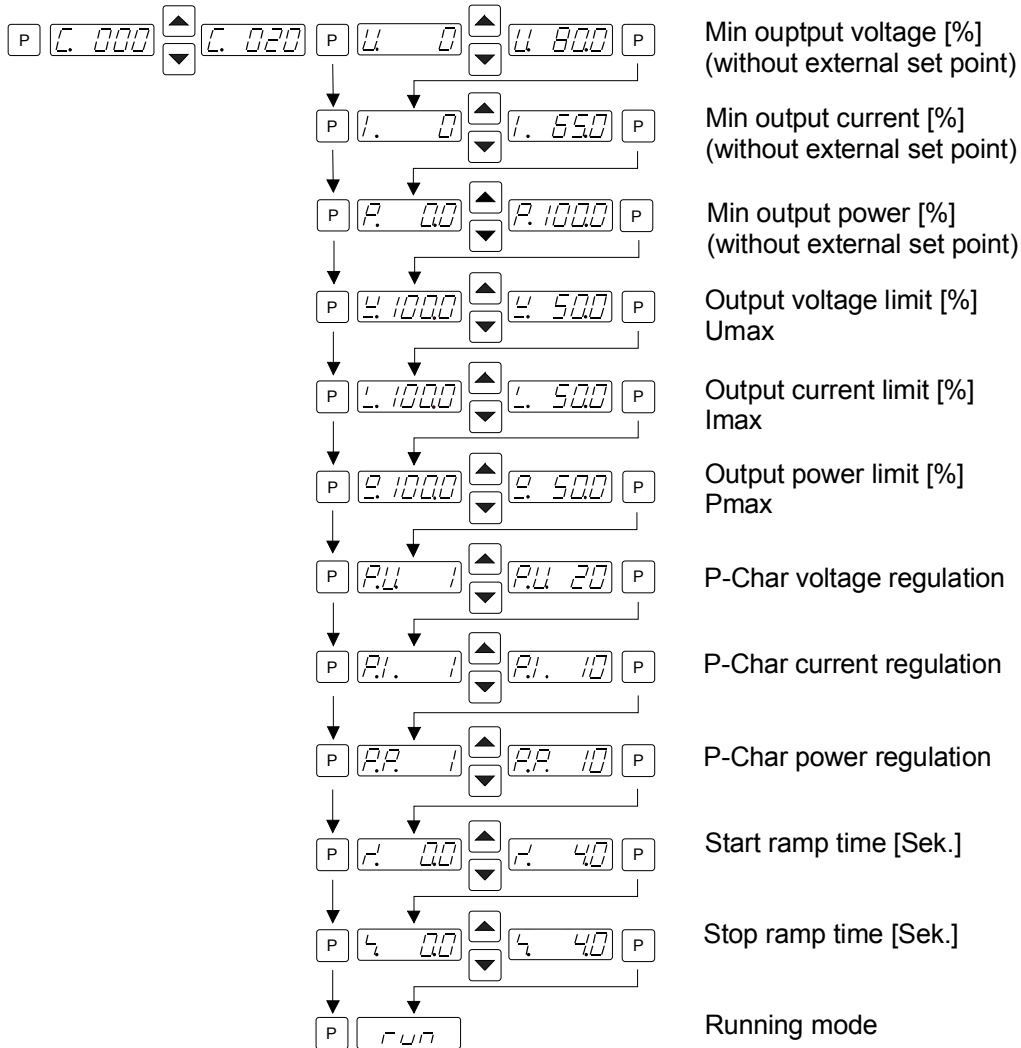

9.4 Select Interface

Code C 017

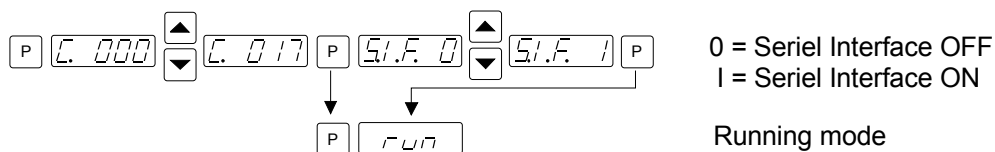

For using the unit without Interface "SIF" must be set to "0"

9.5 Save current settings

Code C 143

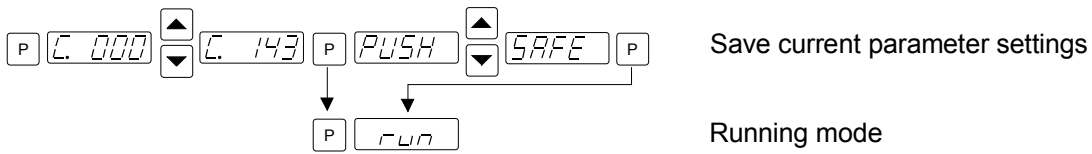

9.6 Restore parameter settings

Code C 210

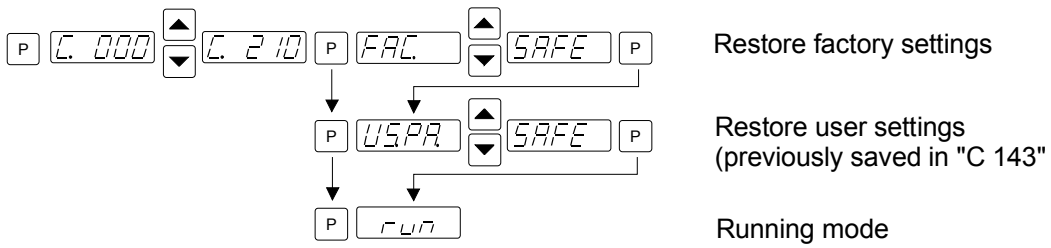

9.7 Hide parameter menus

Code C 117

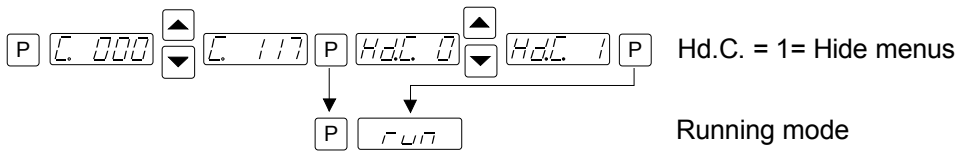

If Hd.C. = 1 all parameter menus are hide. Set Hd.C to "0" again for change parameters.

10.0 Connection diagram

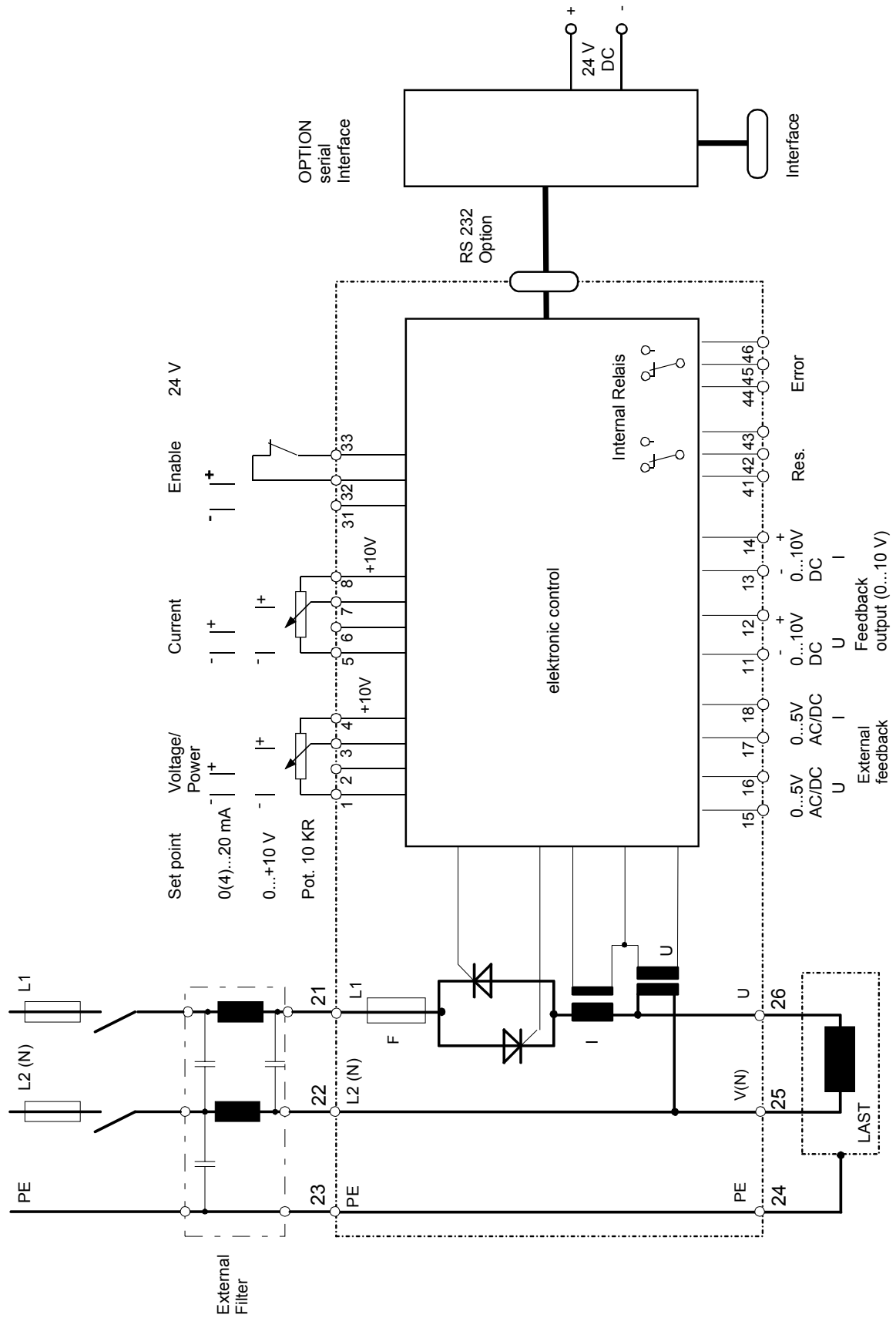

10.1 Connection details

Voltage and current regulation

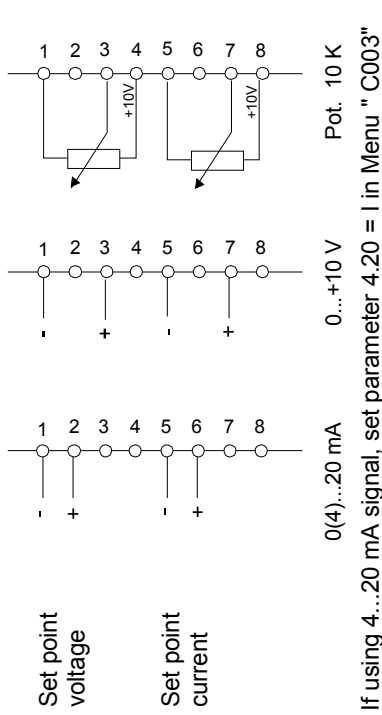

Power regulation

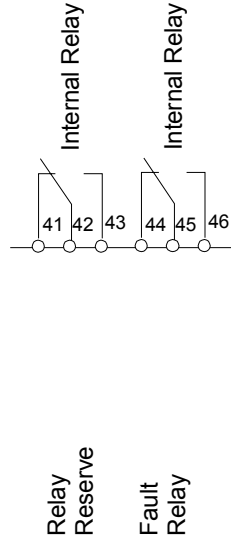
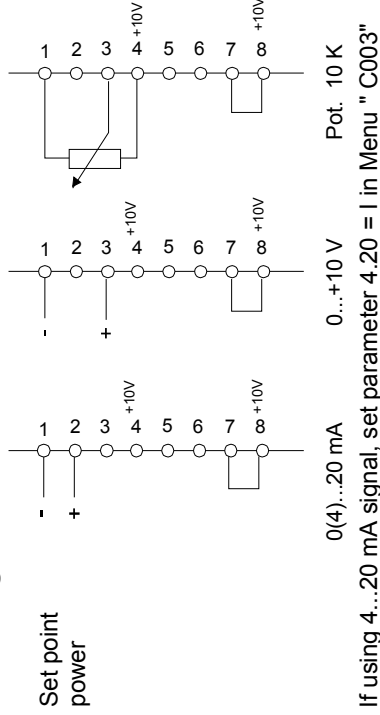

Voltage regulation

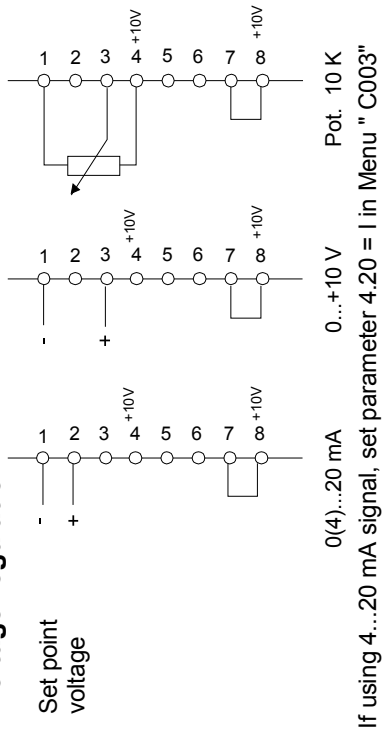

Current regulation

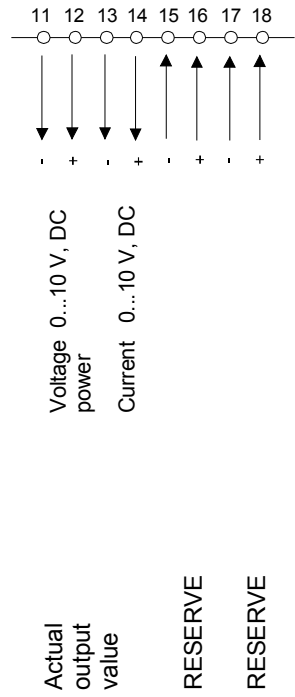
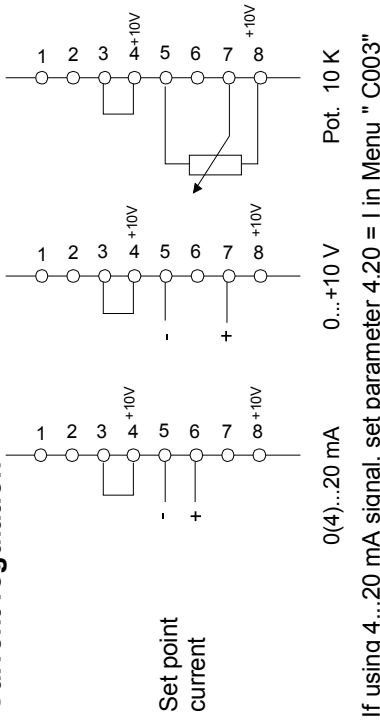

11.0 Dimensions

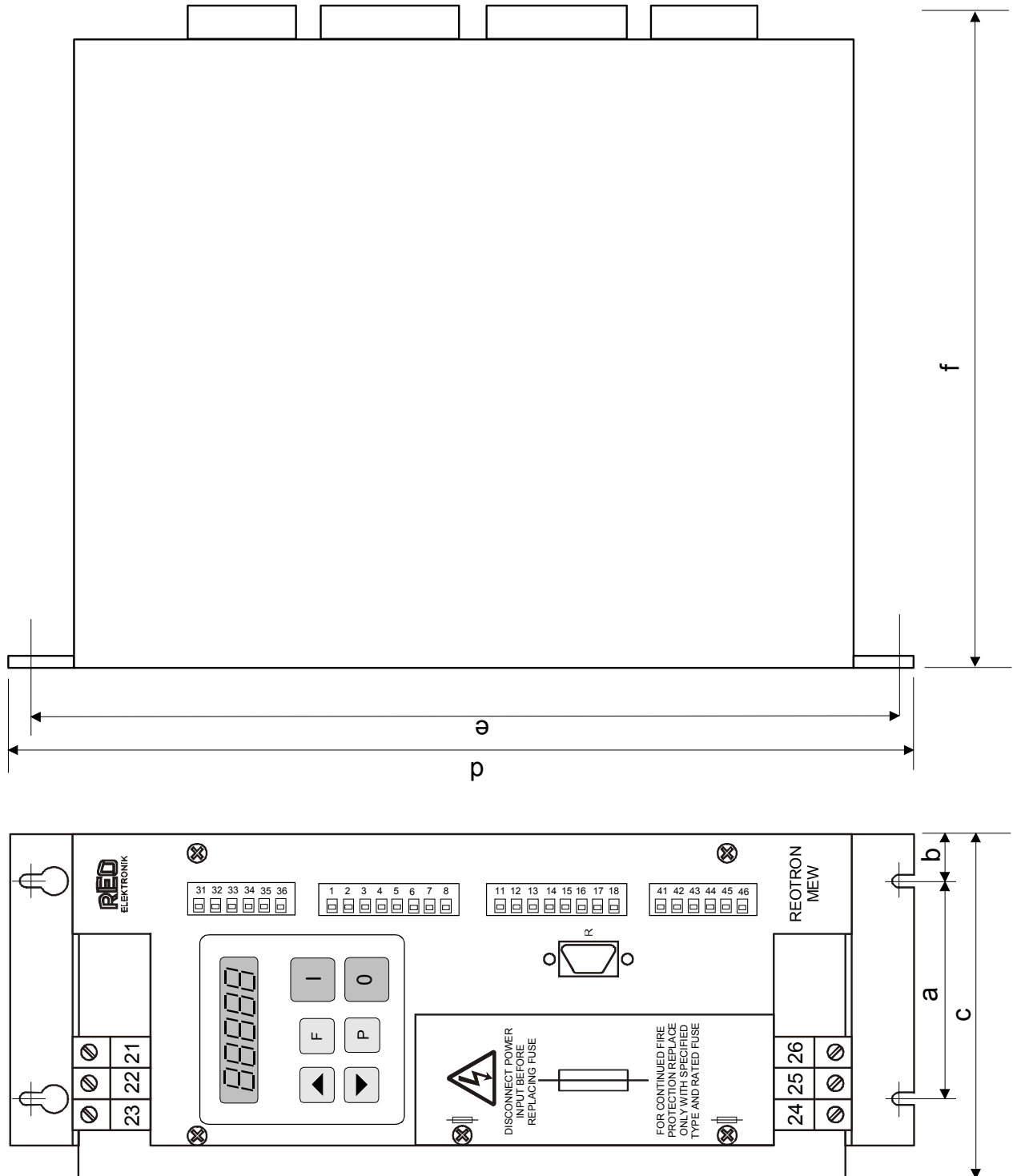

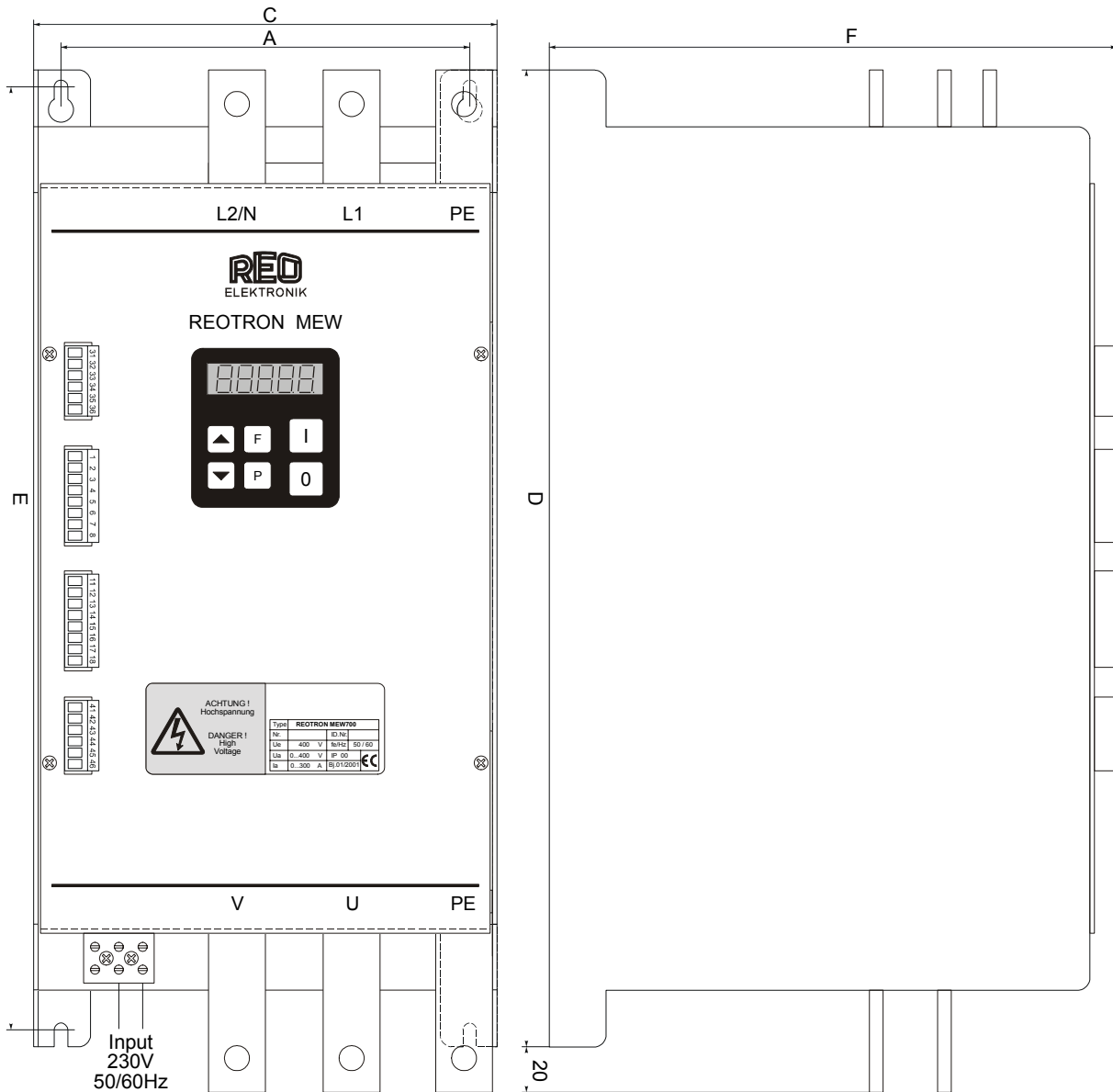

Type / mm	a	b	c	d	e	f
MEW 25	70	15	110	290	280	215
MEW 25 DP	90	15	130	290	280	215
MEW 50	70	15	110	290	280	215
MEW 50 DP	90	15	130	290	280	215
MEW 80	60	30	150	320	304	215
MEW 80 DP	90	30	180	320	304	215
MEW 110	90	30	180	320	304	215
MEW 110 DP	90	30	180	320	304	215
MEW 200	180	12	204	430	415	250
MEW 200 DP	180	12	204	430	415	250
MEW 300	180	12	204	430	415	250
MEW 300 DP	180	12	204	430	415	250

12.0 Putting into service



Safety Instruction

Qualified personnel only, are permitted to install electronic equipment

Because attenuation capacitors (Y-capacitors) are used, leakage current flows through the case to protective earth (PE). Therefore, units **must** be earthed.

12.1 Preliminaries

- Check if the local supply voltage is the same as the rated voltage for the unit (rating plate) and that the load is within the permitted power range.
- Connect the control unit in accordance with the connection diagram.
- Adjust set-points to zero.
- Switch off enable (if used)
- Check if cables are connected correctly.

The control unit is now ready for operation and can be switched on (power supply, enable).

The unit is factory set according to the rating plate i.e. 100% set point equals 100% voltage, current or power.

Set-point control only can be used, in which case no other settings are necessary.

12.2 Measurements and Settings

Because of the phase-angle-control, the shapes of the supply voltage and current sine curves are changed. The output voltage and current must be measured with effective value meter (true-RMS).

12.3 Putting into service without a proper load

A thyristor can only be switched ("fired") into a conducting state, if the current level is sufficiently high enough. It will only switch-off, if the current is lower than the threshold current (every time the current goes through the zero-crossing point). When the thyristor controller is put into service, without a proper load, realistic measurements such as the voltage, for example, cannot be obtained. Even the setting of the output current i.e. limit, can only be done with a proper load and not by short circuiting the output of the thyristor controller. This is because the thyristor, once "fired", cannot be turned off. The current has to pass through "zero" for the thyristor to switch off. Using a low impedance load it is not possible to evaluate the current level from the internal current flow.

If a proper load is not available or not possible to carry out the correct commissioning procedure then a makeshift test can be carried by connecting a resistive load, such as incandescent lamps to the output of the thyristor controller.

13.0 Installation of Thyristor Control Units

13.1 Fuses

The REOTRON MEW... series of thyristor controllers are fitted with semiconductor fuses, which protect the power semiconductors (thyristors) from damage when there is a short-circuit on the output. These fuses are selected for the permitted peak current of the semiconductors and are not provided for protection against overload or line faults! Fuses are provided only in the current-carrying circuits with thyristors.

Fuses for overload, line and earth fault protections should be fitted to the incoming power side.

13.2 Incoming breaker

An isolator must be connected in front of a thyristor-controller, mounted inside a control panel (VDE 0160/6.3.1) because of the leakage-current from a high-impedance thyristor and hence the current flow through the protection circuit. This can be used to disconnect the unit from mains supply before a routine shut-down.

Because all REOTRON thyristor-controllers have an enable input, it is possible to inhibit the input pulses, and hence firing of the thyristors, until the main contactors have securely closed or before the contactors open again when shutting down.

When enable inputs are used in this way, the contactors can be rated for current-free switching, in which case AC1 would be suitable. If direct-on-line switching is used i.e. by switching the thyristor controller, without using the enable, the rating of the contactors must be in accordance with AC3.

13.3 Output Breaker

A circuit-breaker on the output of the thyristor controller should be avoided, because it cannot operate without a load. Current or voltage monitoring in the output of the thyristor controller must be used to control the circuit-breaker at the input side.

Current-free switching of the thyristor controllers' output (e.g. load switching) is possible, however, by using the enable input.

13.4 Installation and climatic Conditions

The mounting base should be free of vibration, if possible. Note that the temperature of the heat-sink rises when a power controller is operating. The heat-sink must be mounted vertically to ensure efficient cooling. The ambient temperature range allowed below the heat-sink is 0°...+45°C. The relative air humidity is < 75% without dew. The clearance below the unit should be at least 100mm and above at least 150mm. There must be a clearance of 50mm between units mounted next to each other. For altitudes above 1000m the power must be derated by 0,5% per 100m additional height.

13.5 Signal cables

Set Points

If external voltage (0...10V) or current (0(4)...20mA) set-points are used; care should be taken to ensure that all equipment is connected through equal-potential bonding. If the bonding is earthed, then this should be at a single point, thus avoiding earthing loops and possible coupled interference.

14.0 Interference prevention

14.1 Earthing

Correct earthing of electronic controls is highly important for two reasons:

First it ensures the safety of operators and service personnel, and secondly it provides a fail-safe operation of the equipment. Therefore, in addition to providing protective earthing, in accordance to DIN standards, it also provides an earth path for pulse interference produced during operation. For the latter, controllers that are mounted onto a chassis-plate in a control panel should be bonded to earth with the shortest possible connection and the largest possible earth contact area and also, for example, onto the centrally bonded chassis-plate. The reason for this is to ground high-frequency interferences produced by switching on the mains (contactors, relays, switches) before they cause fault conditions. If the earth conductors are too long and if they run together with other cables, in one cable duct, then they are unsuitable for grounding high-frequency noise.

The more complex the unit and the more "intelligent" the functions - especially serial bus connections - then the more important it is to use correct earthing techniques.

14.2 Control cables

Control cables also are "antennas" that receive interference produced by other loads. Signal cables that are run alongside power cables can generate voltage spikes through inductive and capacitive cross-coupling. Therefore control conductors should not be mixed with power cables in the same cable ducting. If this cannot be avoided then shielded cables should be used. In particular cables from inverters to motors are very critical because of the presence of high-speed switching. There should be maximum distance between control cables output cables from frequency inverters. The shielding around the control conductors should be grounded onto a large contact area (earthed mounting plate) at the equipment end.

14.3 Interference protection of other external components and equipment

Contactors produce extreme Burst-interferences on switching. Contactor coils must be connected with RC-snubbers. Suitable RC-snubbers can be obtained from switch manufacturers.

Magnets / magnetic valves are also interference sources in the same way as contactors. RC- snubbers and varistors can be components and varistors can be connected across these components

Frequency inverters are to connect to a mains filter recommended by the manufacturer.

Motor wires should be shielded and routed away from control cables.

Annex Profibus-DP

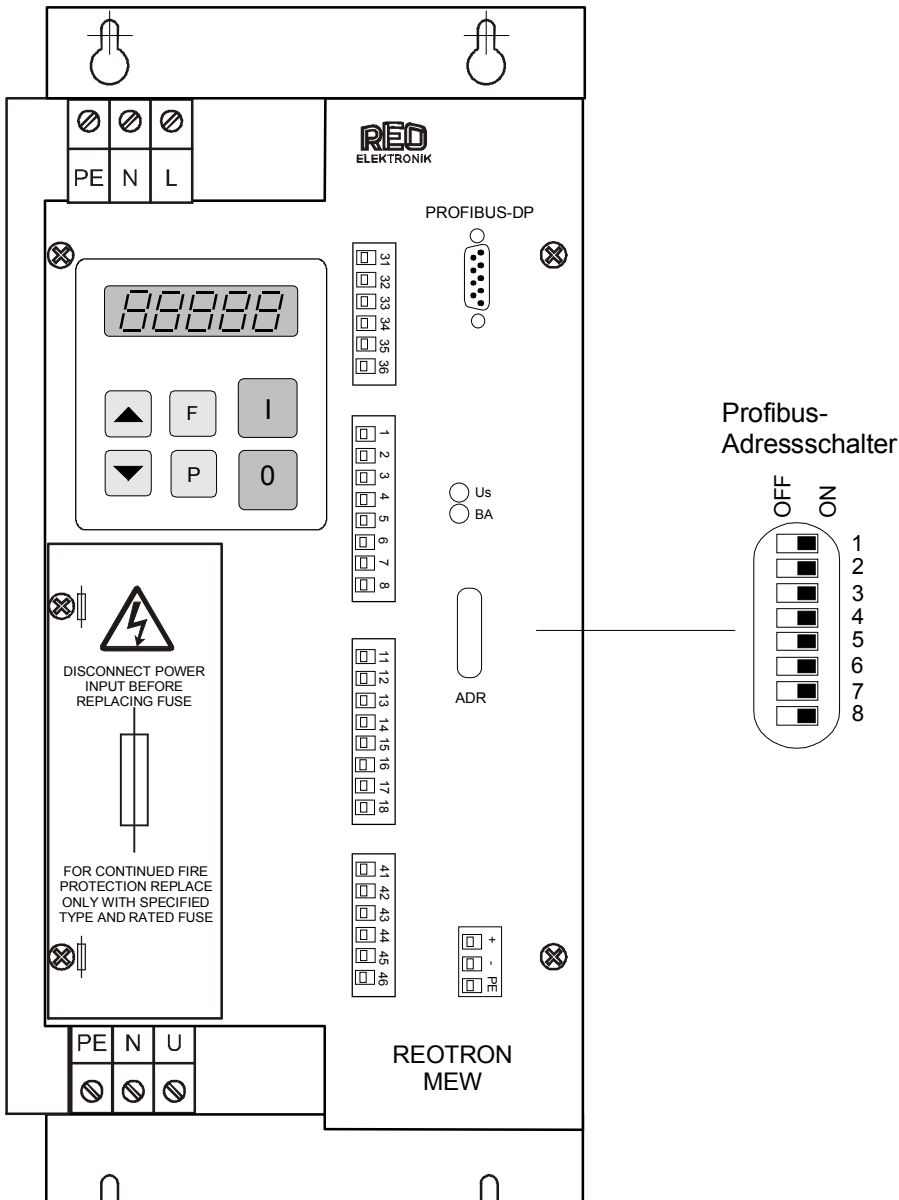

Programming for Bus operation

In normal operation the set points for output voltage and current limit and the digital control signals, such as enable are set across the interface. The actual voltage/current values and unit status (ready or fault) are fed back.

All data words are within the range 0...FFFF H

The following communication words are given in bit form

Send to Controller

H-Byte								L-Byte								Word 1
15	14	13	12	11	10	9	8	7	6	5	4	3	2	1	0	Voltage Setpoint (Power Setpoint) 16-Bit, 100 % = FFFF H
H-Byte								L-Byte								Word 2
15	14	13	12	11	10	9	8	7	6	5	4	3	2	1	0	Current Setpoint, 16 Bit, 100 % = FFFF H
H-Byte								L-Byte								Word 3
15	14	13	12	11	10	9	8	7	6	5	4	3	2	1	0	Control word Bit = `1` = Function ON All unused bits MUST be set to `0`
0	Mode bit	0	Powerregulation	0	0	0	0	0	0	0	0	0	0	0	0	
Control Information (unit specific)																

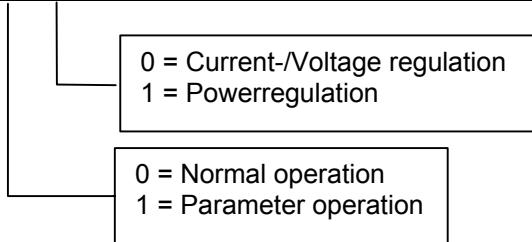

Reply from Controller

H-Byte								L-Byte								Word 1
15	14	13	12	11	10	9	8	7	6	5	4	3	2	1	0	Actual voltage 16 Bit, 100 % = 8000 H (Actual power 16 Bit 100 % = 4000 H)
H-Byte								L-Byte								Word 2
15	14	13	12	11	10	9	8	7	6	5	4	3	2	1	0	Actual current 16 Bit, 100 % = 8000 H
H-Byte								L-Byte								Word 3
Fault – Code								7 6 5 4 3 2 1 0 X X X Enable X X X X Status - Word X = Not defined Bit = `1` = Function ON								
00 Unit not responding 70 (H) Over temperature 58 (H) Over load A5 (H) Unit Ready C0 (H) Acknowledge Parameter mode								Status information Unit specific								

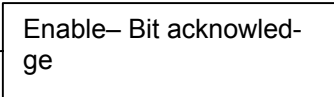

Only the unit status is received.

Parameter Operation

In parameter operation, the specific unit parameters can be monitored and adjusted.

A `write` enable must be transmitted before parameters can be altered. On closed the `write` enable must be cancelled.

A `read` request must be sent before data can be read.

Word 3 in the acknowledge is always `CODE H`. This indicates that the controller is in parameter mode.

Creating parameter address's and values

In parameter operation the most significant bit (msb) in Word 1 is defined as a read or write bit (R/W), where 1 = write and 0 = read, this should be accompanied by the corresponding parameter address.

The mode bit (msb in Word 3) is used to select normal or parameter operation, 0 = Normal or 1 = Parameter operation.

Word 1:	R/W – Bit + Address	e.g. 8000 H + 1009 H => 9009 H
Word 2:	Value of the parameters	e.g. 7FFF H
Word 3:	Mode bit = 1 + control bits	e.g. 8000 H + 0004 H => 9004 H

For bit orientated parameters, ONLY those bits relating to the required function may be changed, all other bits MUST remain unaltered, otherwise factory specific settings may be inadvertently altered!

Procedure for changing bit parameters:-

1. Select parameter value
2. Change only the required bit (s) in the selected parameter
3. Send `write` enable
4. Send the changed parameters back to the same address
5. Close the `write` enable

Parameter Table

Non listed addresses cannot be altered!

Parameters:		Display-Code	Factory settings:	Parameter-address hEX (.bit)	Value
Set point					
• Spannungssollwert	0...100 %	U.	0 %	100C	0...65535
• Stromsollwert	0...100 %	I.	0 %	100A	0...65535
• Leistungssollwert	0...100 %	P.	100 %	100B	0...65535
Configuration					
• External set point OFF	0 / 1	E.S.O.	0	1800.0	Bit
• 4...20 mA (only when E.S.P. = I)	0 / 1	4.20.	0	1800.1	Bit
• Enable Inverse	0 / 1	-En.	0	1801.1	Bit
• External Voltage set point	0 / 1	E.F.U.	0	1800.2	Bit
• External Current set point	0 / 1	E.F.I.	0	1800.3	Bit
• Full wave control	0 / 1	E.F.P.	0	1801.6	Bit
Parameter					
• Maximum Output Voltage (Limit)	25...100 %	U.	100 %	1009	16384... 65535
• Maximum Output Current (Limit)	25...100 %	I.	100 %	1008	16384... 65535
• Maximum Output Power (Limit)	25...100 %	p.	100 %	1008	16384... 65535
• Voltage Regulator – P characteristic	1...100	P.U.	20	100F	655...65535
• Current Regulator – P characteristic	1...100	P.I.	15	100D	655...65535
• Power Regulator – P characteristic	1...100	P.P.	20	100E	655...65535
• Soft- start	0...60 sec.	/.	0,1	1013	0...65535
• Soft- stop	0...60 sec.	\.	0,1	1012	0...65535
Interface					
• Interface mode ON	0 / 1	S.I.F.	0	1801.8	Bit

Example of bus communication

Variable values are shown in *italics*

Normal mode

Set setpoint to 70 %

Send Setpoint	Word	Code	Send	Code	Received
	1	B332 H	Setpoint = 70 % voltage	---	---
	2	FFFF H	Setpoint = 100% current	---	---
	3	0004 H	Enable ON	A5xx H	Ready

Enable ON, Stop controller (with enable)

Send Setpoint	Word	Code	Send	Code	Received
	1	B332 H	Setpoint = 70 %	---	---
	2				
	3	0000 H	Enable OFF	A5xx H	Ready

Parameter Operation

e.g. Set Soft Start time to 2 seconds

Open Write Enable	Word	Code	Send	Code	Received
	1	C0DE H	Enable Address	C0DE H	Acknowledge
	2	B5E7 H	Write enable value	B5E7 H	Acknowledge
	3	8000 H + control bit	Set mode bit = 1	C0DE H	Acknowledge

Write Parameter	Word	Code	Send	Code	Received
	1	9013 H	Parameter address Soft start + R / W - Bit	9013 H	Acknowledge
	2	3333 H	Soft start 2 Sec	3333 H	Acknowledge 2 Sec
	3	8000 H + control bit	Set mode bit = 1	C0DE H	Acknowledge

Close write enable	Word	Code	Send	Code	Received
	1	C0DE H	Enable Address	C0DE H	Acknowledge
	2	0000 H	Write enable value	0000 H	Acknowledge
	3	8000 H + control bit	Set mode bit = 1	C0DE H	Acknowledge

Parameter Read Only

Read	Word	Code	Send	Code	Received
	1	1013 H	Parameter address Soft start	1013 H	Acknowledge
	2	0000 H	Read parameter	8000 H	Parameter value (=> 5 secs)
	3	8000 H + control bit	Set mode bit = 1	C0DE H	Acknowledge parameter mode

Example of bit parameter change

Read Parameter	Word	Code	Send	Code	Receive
	1	1800 H	Parameter address	1800 H	Acknowledge
	2	0000 H	Parameter read	0000 H	Parameter value
	3	8000 H + control bits	Set mode bit = 1	CODE H	Acknowledge parameter mode

Change bit in selected parameter value
(e.g. Set bit 1 at address 1800 H to 1 = 4...20 mA).

Write Enable	Word	Code	Send	Code	Receive
	1	C0DE H	Write enable address	C0DE H	Acknowledge
	2	B5E7 H	Write enable value	B5E7 H	Acknowledge
	3	8000 H + control bits	Set mode bit = 1	C0DE H	Acknowledge

Write Parameter	1	9800 H	Parameter address	9800 H	Acknowledge
	2	0002 H	New parameter	0002 H	Acknowledge
	3	8000 H + control bits	Set mode bit = 1	C0DE H	Acknowledge

Close Write enable	Word	Code	Send	Code	Receive
	1	C0DE H	Write enable address	C0DE H	Acknowledge
	2	0000 H	Write enable value	0000 H	Acknowledge
	3	8000 H + control bits	Set mode bit = 1	C0DE H	Acknowledge

RESET Controller

Open Write enable	Word	Code	Send	Code	Receive
	1	C0DE H	Write enable Address	C0DE H	Acknowledge
	2	B5C9 H	Write enable Value	BC97 H	Acknowledge
	3	8000 H + control bits	Set mode bit = 1	C0DE H	Acknowledge

Write Parameter	1	9400 H	Parameter address Reset + R / W - Bit	9400 H	Acknowledge
	2	C009 H	RESET.	C009 H	
	3	8000 H + control bits	Set mode bit = 1	C0DE H	

Allow approximately 0.5 secs for RESET