



Operating Instructions
REOTRON SMP
Power Supply

REO (UK) LTD
Units 8 & 9
Long Lane Industrial Estate
Craven Arms, Shropshire
Tel. 01588 673411
Fax 01588 672718
<http://www.reo.co.uk>
eMail: main@reo.co.uk

REOTRON

Electronic Power Controller

Technical safety information for the user

This description contains the necessary information for the correct application of the product described below. It is intended for use by technically qualified personal.

Qualified personnel are persons who, because of their training, experience and position as well as their knowledge of appropriate standards, regulations, health and safety requirements and working conditions, are authorised to be responsible for the safety of the equipment, at all times, whilst carrying out their normal duties and are therefore aware of, and can report, possible hazards (Definition of qualified employees according to IEC 364)

Safety Instructions

The following instructions are provided for the personal safety of operators and also for the protection of the described product and connected equipment.



Warning!

Hazardous Voltage

Failure to observe can kill, cause serious injury or damage

- Isolate from mains before installation or dismantling work, as well as for fuse changes or post installation modifications.
- Observe the prescribed accident prevention and safety rules for the specific application.
- Before putting into operation check if the rated voltage for the unit conforms with the local supply voltage.
- Emergency stop devices must be provided for all applications. Operation of the emergency stop must inhibit any further uncontrolled operation.
- **Electrical connections must be covered**
- **The earth connection must be checked, for correct function, after installation.**

Specified Use

The units described herein are electrical controllers for installation in industrial equipment. Not suitable for domestic applications.

Contents

Technical safety information for the user 1

Contents 2

1.0 General 3

2.0 Functions..... 3

 3.0 Fault conditions 4

4.0 Combining several units..... 4

5.0 Technical Data 4

6.0 Controls..... 5

 6.1 Description of controls 5

 6.2 How to use the controls..... 5

 6.3 Setting procedure 5

 6.4 Displays 6

 6.4.1 Operating modes..... 6

 6.4.2 Fault displays..... 6

6.5 Parameter settings and ranges..... 7

7.0 Settings 8

 7.1 Configure 8

 7.2 Minimum and maximum values 8

 7.3 Limit switches 8

 7.4 Reset error messages 9

 7.5 Save user settings 9

 7.6 Recall saved settings 9

 7.7 Hide / display menus 9

8.0 Connections 10

9.0 Dimensions 12

10.0 Connection example 13

1.0 General

Primary switching circuit with DC output. Internal regulator for voltage, current or power control. Controlled from two setpoints (setpoint 1 = voltage, setpoint 2 = current) using either a 0...10 V, 0(4)...20 mA analogue signal or a Potentiometer. Setpoint 1 is used in the power regulation mode. The touch panel is used for making settings and keys "I" and "O" can be used for switching the output ON and OFF. **However, this not provide isolation of the mains input.** A maximum of up to four units can be used in parallel or series connection for providing higher power outputs.

Operating principles

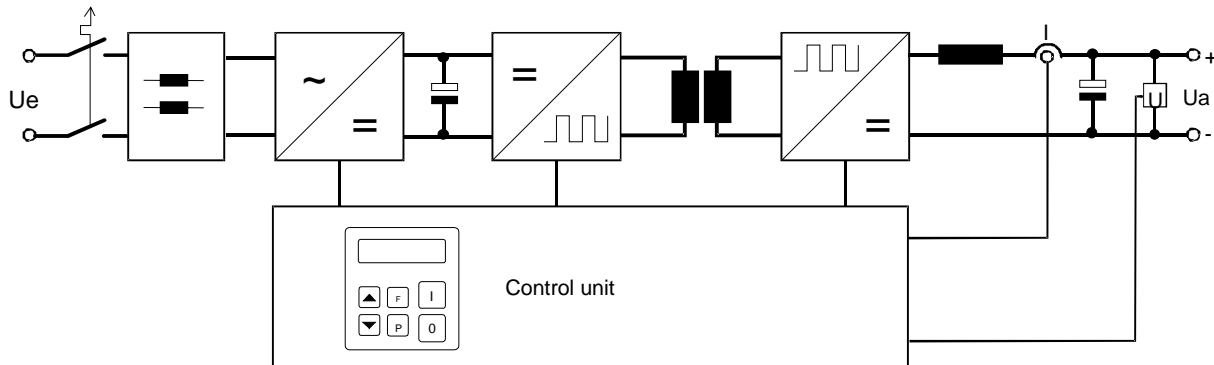

2.0 Functions

Input:		Terminals
Set point 1	Voltage set point: 0...10 V, DC, 0(4)...20 mA or Potentiometer 10 k Or power set point	1(-), 3(+), 4(+10V) / 2 (+) for 0...20 mA
Set point 2	Current set point: 0...10 V, DC, 0(4)...20 mA or Potentiometer 10 k	5(-), 7(+), 8(+10V) / 6 for 0...20 mA
Enable	Contact or 24 V, DC signal voltage	31(-), 32(+), 33(+24V)

Enable:

24 V, DC signal on enable input (24V = ON).

External contact on terminals 32 and 33 or external 24 V signal on terminals 31(-) and 32(+).

Voltage regulation (Set point 1)

Set point 2 (Current) at +10V Ref. Link between terminals 7 and 8.

Connect voltage set point to terminals 1 – 4 (see connection diagram).

A maximum output current limit can be set in menu "C. 006".

Current regulation (Set point 2)

Set point 1 (voltage) at +10V Ref. Link between terminals 3 and 4.

Connect voltage set point to terminals 5 - 8 (see connection diagram).

A maximum voltage limit can be set in menu "C. 006".

Power regulation (Set point 1)

Set point 2 (Current) at +10V Ref. Link between terminals 7 and 8.

Connect power set point to terminals 1 – 4 (see connection diagram).

A maximum output current limit can be set in menu "C. 006".

IMPORTANT:

The complete power range can only be used with a correctly sized load.

3.0 Fault conditions

Faults conditions are displayed for:

Over temperature	Error	HOT
Low mains voltage	Lo.Po.	
High mains voltage	Error	OU

When a fault condition occurs the unit switches itself off and an error message is displayed. The error message must be cancelled in menu "C 009".

4.0 Combining several units

It is possible to connect up to four units in series or in parallel. When parallel connection is used the outputs should be wired to a common terminal but in series connection the units can be linked together. In all cases the set points are connected in parallel. When a 0(4)...20 mA control signal is used a 500 ohm resistor must be connected across terminals 1 + 3 and 5 + 7 respectively. The current source must be capable of delivering at least 10V.

5.0 Technical Data

Unit type	REOTRON SMP 30 / 35
Input voltage	240 V, +/- 10%
Input frequency	50 / 60 Hz
Unit output power	1050 VA
Output current	0...35 A
Output voltage	0...30 V, DC
Switch on duty cycle	30 / h
Enclosure	IP 20
Contact protection	VBG 4
Operating temperature	0...+45 °C
Storage temperature	-20...+70 °C
Mounting method	Vertical (terminals at the bottom)

6.0 Controls

6.1 Description of controls

The unit is operated and set up by using six buttons that are used in conjunction with a LED display, in the front touch panel. All configuration and parameter settings can be made through this panel. The unit can be switched ON and OFF by using the “I” and “O” keys, however these **do not provide mains isolation**, they simply inhibit or enable the power semiconductors.

The “P”, “F” and arrow keys are used for setting the parameters.

The parameter settings are held under menu control that are opened by entering user codes. A later section on settings provides a fuller description of menus.

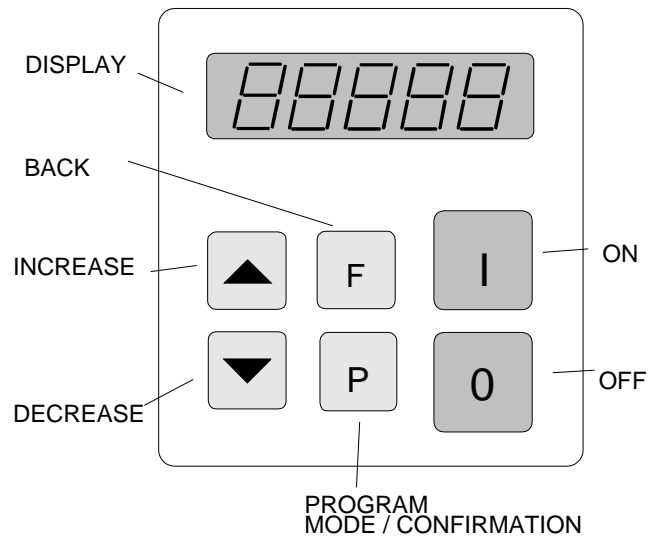

6.2 How to use the controls

Pressing the arrow key for short time will increase or decrease the displayed value by one division (a unit or tenth). The display will change in tens of units when the arrow keys are held down. To prevent unauthorised changes to the settings these are protected under operating menus. A user code must be entered to open the menus. There are different menus for the various functions.

New values are saved upon leaving the programming mode or when a key is not pressed for 100 seconds.

6.3 Setting procedure

Every adjustment is made by firstly pressing the programming key “P”. The following flow diagram should help in clarifying the procedure:

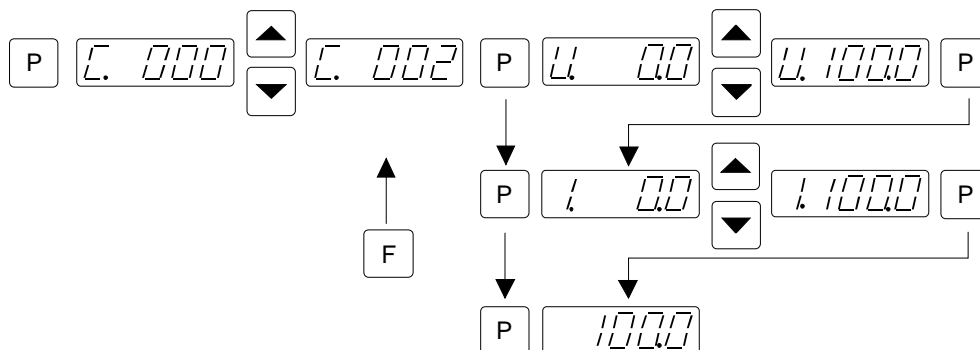

1. Press the “P-Key”.
2. Select the Code Number by using the arrow keys.
3. Press the “P-Key” again. The first menu position will be displayed. Further menu positions will be displayed by repeatedly pressing the “P-Key” (scrolling).
4. When the required menu position has been reached, the setting can be changed with the arrow keys.
5. Continue pressing the “P-Key” for the next menu position or until the end position is reached ie when the setpoint is displayed. To exit the menu quickly press the “P-Key” for a long time (5 secs.).
6. The “F-Key” allows the user to go back to a previous menu point..

6.4 Displays

During normal operation "run" is displayed on the LED panel. In the programming mode a shortened description of the function is displayed. New settings are upon when leaving the programming mode or if no keys are pressed for 30 seconds delay, then the settings will be saved.

6.4.1 Operating modes

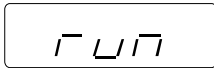

Normal operation

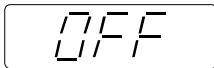

No unit enable

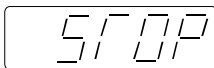

Unit stopped by using the "O-Key"

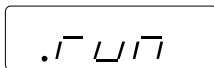

Illuminated left-hand, decimal point in the display. Current regulation, maximum current for the unit or the selected current limit has been reached.

6.4.2 Fault displays

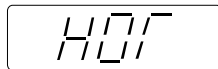
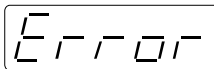

Over temperature

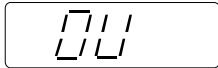
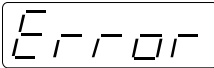

Input voltage too high

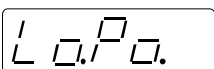

Input voltage too low

6.5 Parameter settings and ranges

Parameter		Code	Factory Settings:	Pass Code
• Disable external set point	0 / I	E.S.O.	0	003
• 4...20 mA	0 / I	4.20	0	003
• Power regulation	0 / I	E.F.P.	0	003
• Minimum voltage	0...100 %	U.	0	006
• Minimum current	0...100 %	I.	0	006
• Maximum power	0...100 %	P.	100	006
• Maximum voltage	50...100 %	u.	100	006
• Maximum current	50...100 %	i.	100	006
• Output voltage limit switch MIN	0...100 %	L.	0	007
• Output voltage limit switch MAX	0...100 %	H.	100	007
• Error reset		Clr.Er.		009
• Save settings		PUSH.		143
• Return to factory settings		FAC.		210
• Return to user settings		US.PA.		210
• Disable programming modes	0 / I	Hd.C.	0	117

7.0 Settings

7.1 Configure

Code 003

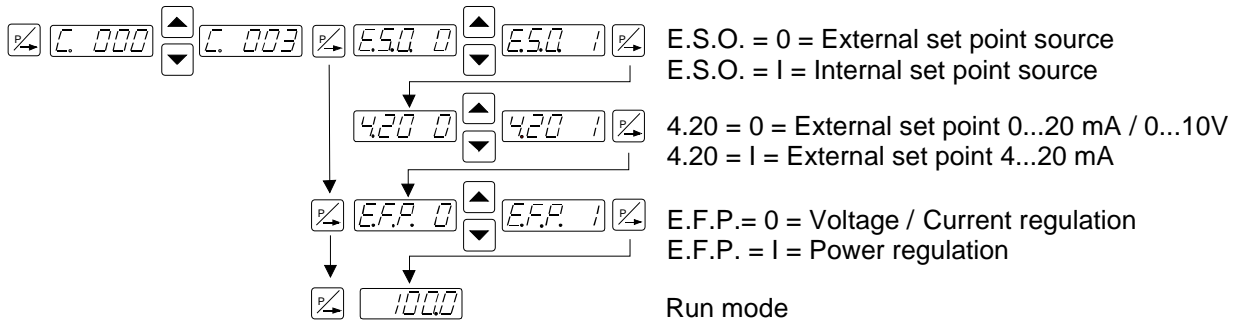

7.2 Minimum and maximum values

Code 006

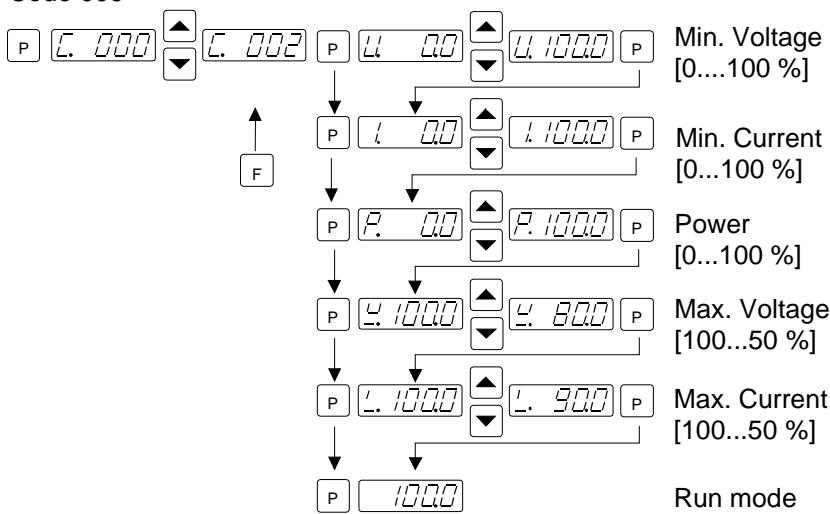

7.3 Limit switches

Code 007

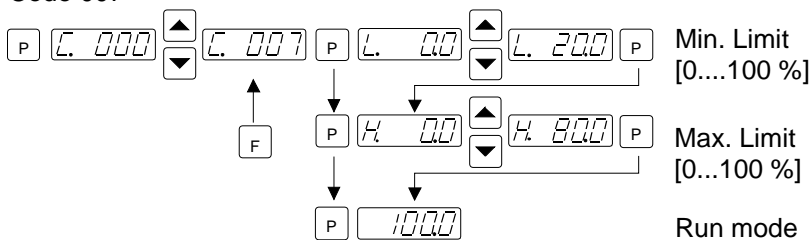

7.4 Reset error messages

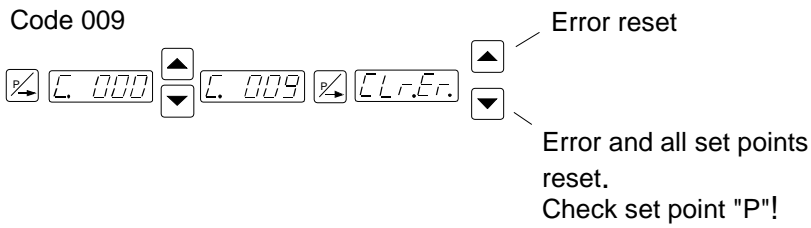

7.5 Save user settings

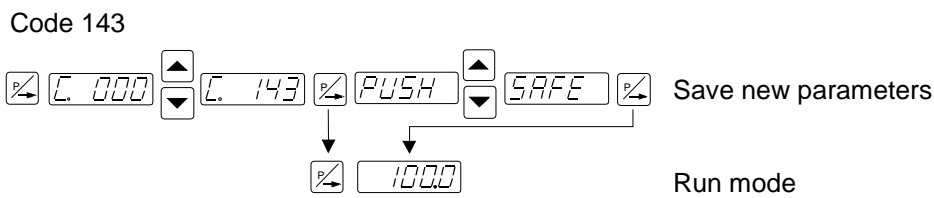

7.6 Recall saved settings

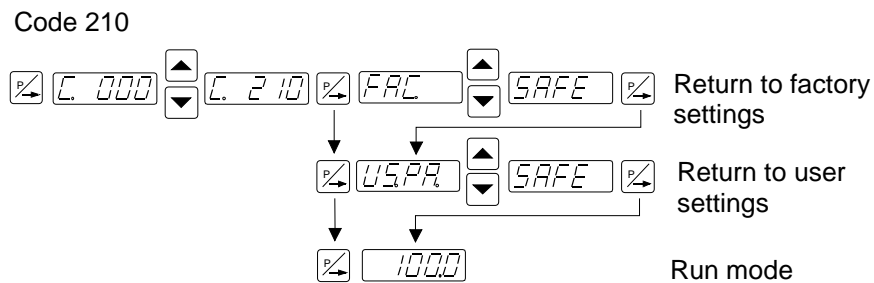

7.7 Hide / display menus

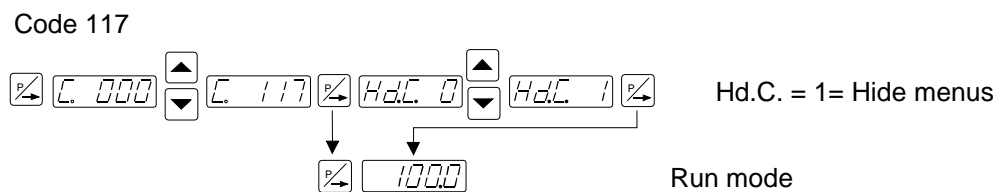

8.0 Connections

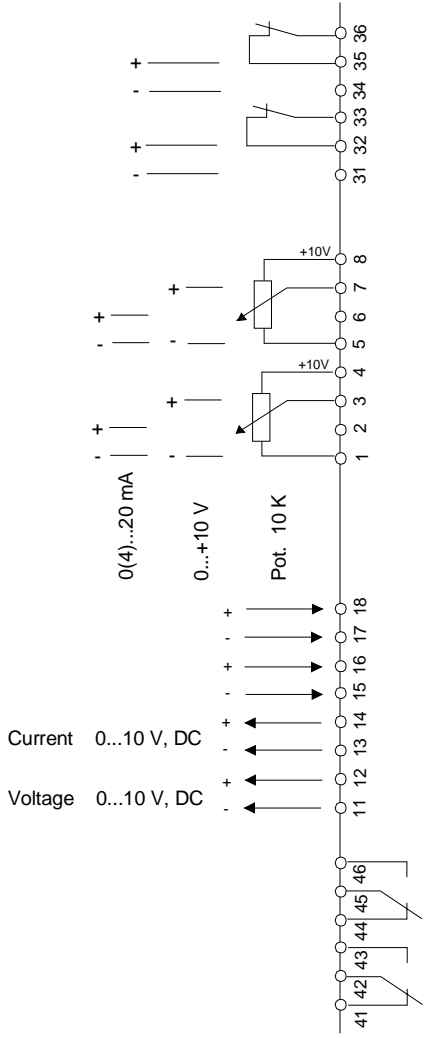
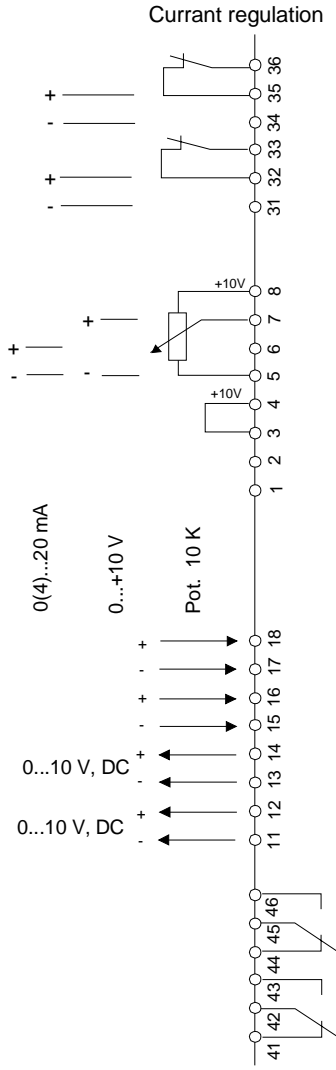
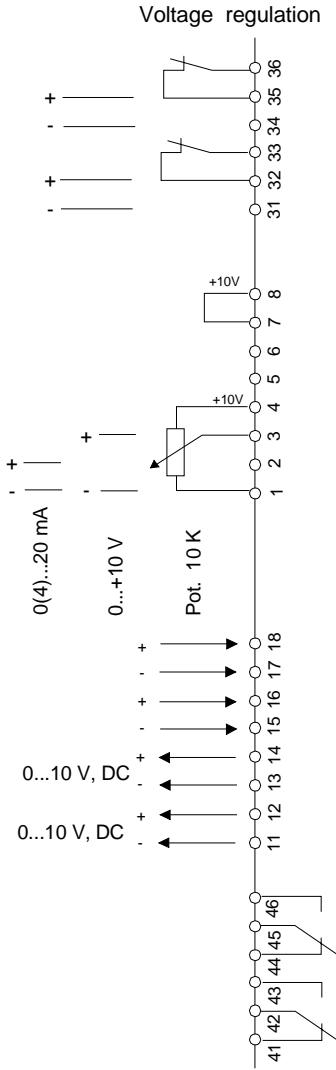

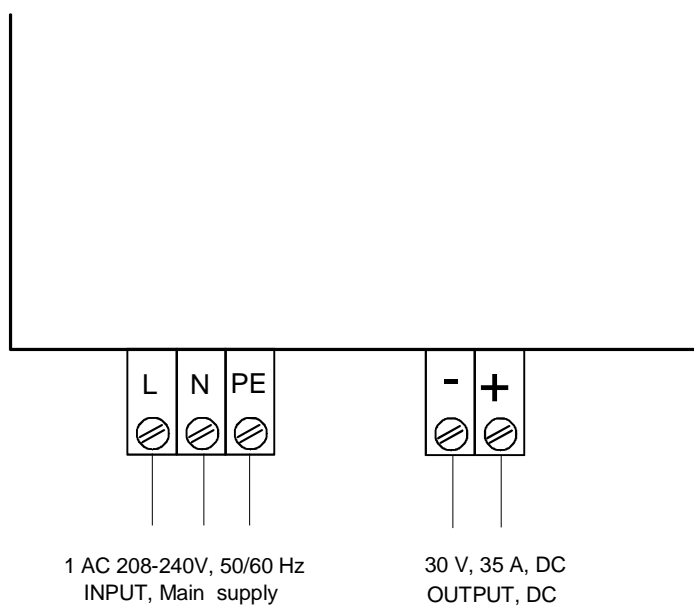

Power connections

9.0 Dimensions

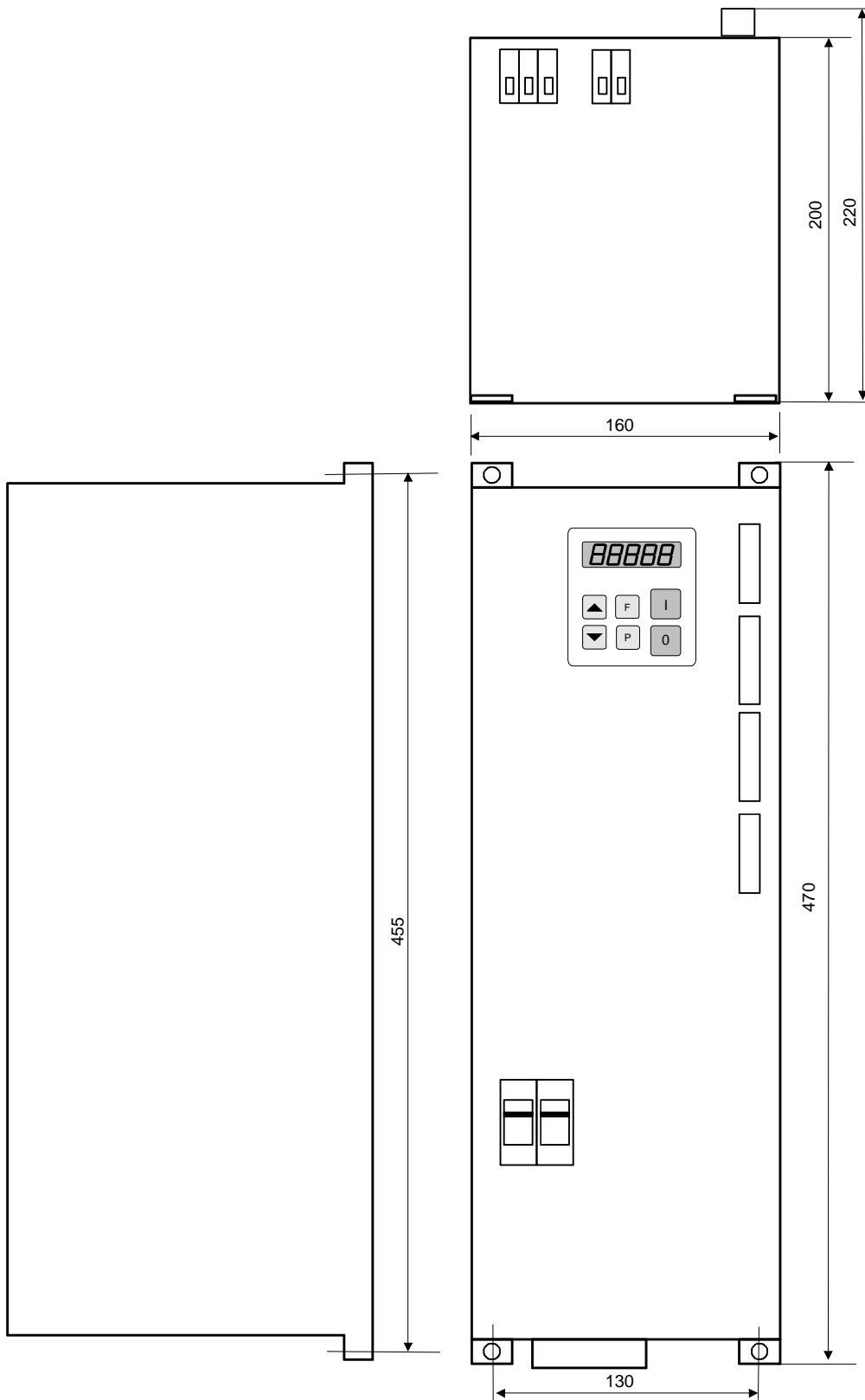

10.0 Connection example

Parallel connection

